

ACBMV B. CASADIO VIBRATION
 Z.I. Mi-Plaine
 51 Rue Ampère
 B.P. 31
 69682 CHASSIEU CEDEX (FRANCE)
 Tel.: 04 78 90 87 87 / Fax.: 04 78 90 87 88
 Email: vibrateur@orange.fr
 Internet: acbm.com

3000/3600 RPM ATEX III 3D tD A22 IP 65 ZONE 22
 REF.: 600450H Dust T°=100°C

Certifications:



MECHANICAL AND ELECTRICAL SPECIFICATIONS

Eccentric weight setup (%)	Static moment (kgmm)	Working moment (kgcm)	Centrifugal force (kg)	Centrifugal force (N)	Estimated bearings life time (hours)
100	4,5	0,90	45 (50Hz)	441 (50Hz)	8087 (50Hz)
			65 (60Hz)	638 (60Hz)	2236 (60Hz)
90	4,05	0,81	41 (50Hz)	397 (50Hz)	11093 (50Hz)
			59 (60Hz)	574 (60Hz)	3067 (60Hz)
80	3,60	0,72	36 (50Hz)	353 (50Hz)	15795 (50Hz)
			52 (60Hz)	510 (60Hz)	4367 (60Hz)
70	3,15	0,63	32 (50Hz)	309 (50Hz)	23577 (50Hz)
			46 (60Hz)	447 (60Hz)	6519 (60Hz)
60	2,70	0,54	27 (50Hz)	265 (50Hz)	37440 (50Hz)
			39 (60Hz)	383 (60Hz)	10352 (60Hz)
50	2,25	0,45	23 (50Hz)	221 (50Hz)	64696 (50Hz)
			33 (60Hz)	319 (60Hz)	17888 (60Hz)
40	1,80	0,36	18 (50Hz)	176 (50Hz)	>100000 (50Hz)
			26 (60Hz)	255 (60Hz)	34938 (60Hz)
30	1,35	0,27	14 (50Hz)	132 (50Hz)	>100000 (50Hz)
			20 (60Hz)	191 (60Hz)	82815 (60Hz)
20	0,90	0,18	9 (50Hz)	88 (50Hz)	>100000 (50Hz)
			13 (60Hz)	128 (60Hz)	>100000 (60Hz)
10	0,45	0,09	5 (50Hz)	44 (50Hz)	>100000 (50Hz)
			7 (60Hz)	64 (60Hz)	>100000 (60Hz)

Power supply (volts)	400
Phases:	three phases
Frequency (Hz)	50 Hz/60 Hz
Rotation speed (RPM)	3000
Max input power (watt)	45
Max current (amp)	0,16

DIMENSIONAL SPECIFICATIONS (mm)

Vibrator weight: 2,2 kg

Continual service ambient temperature: -20°C à +40°C - Tropicalization anti-mold - Mechanical protection: IP66 IK08 according to IEC

Bearing type: BALL

Lubrication "FOR LIFE" with double protection screen

Fixing with 4 screws M6 quality 8.8 with tightening torque (kgm - ft/lb): 7.2 - 1.0

- Cable entry thread: M16x1,5

Maintenance space: 40,5 mm

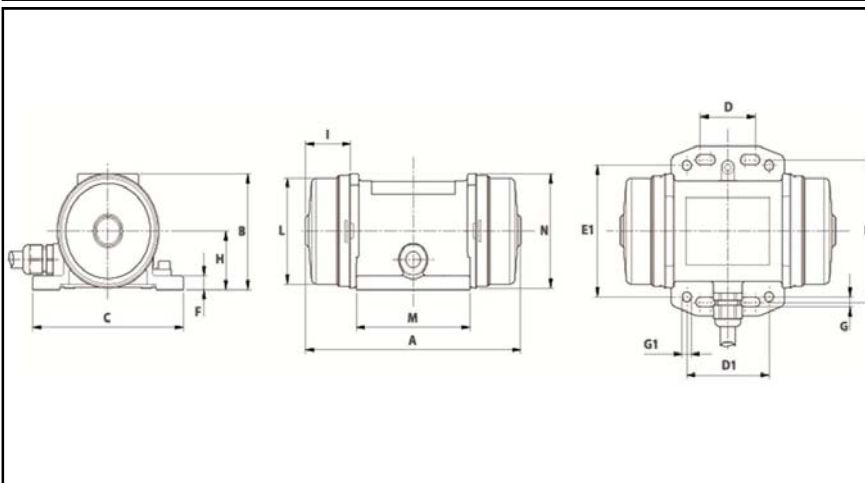

A	172
B	75
C	110
D	25-40
D1	60
E	92
E1	85
F	9
G	6,5
G1	6,5
N° HOLES	8
H	38
I	40,5
L	69
M	83

N					
74					