

ACBMV B. CASADIO VIBRATION
 Z.I. Mi-Plaine
 51 Rue Ampère
 B.P. 31
 69682 CHASSIEU CEDEX (FRANCE)
 Tel.: 04 78 90 87 87 / Fax.: 04 78 90 87 88
 Email: vibrateur@orange.fr
 Internet: acbmv.com

0-6000 RPM
 REF.: 600508A
 SIZE: AF33
 Certifications:



MECHANICAL AND ELECTRICAL SPECIFICATIONS

Eccentric weight setup (%)	Centrifugal force (kg)	Centrifugal force (kN)	Estimated bearings life time (hours)
100	1569	15,4	1475
90	1412	13,86	2023
80	1255	12,32	2881
70	1098	10,78	4300
60	941	9,24	6829
50	785	7,70	11800
40	628	6,16	23047
30	471	4,62	54630
20	314	3,08	>100000
10	157	1,54	>100000

Power supply (volts)	400
Phases:	three phases
Frequency (Hz)	100 Hz
Rotation speed (RPM)	6000
Max input power (watt)	1200
Max current (amp)	2,3
IS/IR	4,48

DIMENSIONAL SPECIFICATIONS (mm)

Vibrator weight: 21 kg

Continual service ambient temperature: -20°C à +40°C - Tropicalization anti-mold - Mechanical protection: IP66 IK08 according to IEC

Bearing type: BALL

Lubrication "FOR LIFE" with double protection screen

Fixing with cradle type: RS2

Power supply cable size: 9 à 16 mm - Cable entry thread: M25x1.5

Maintenance space: 63 mm

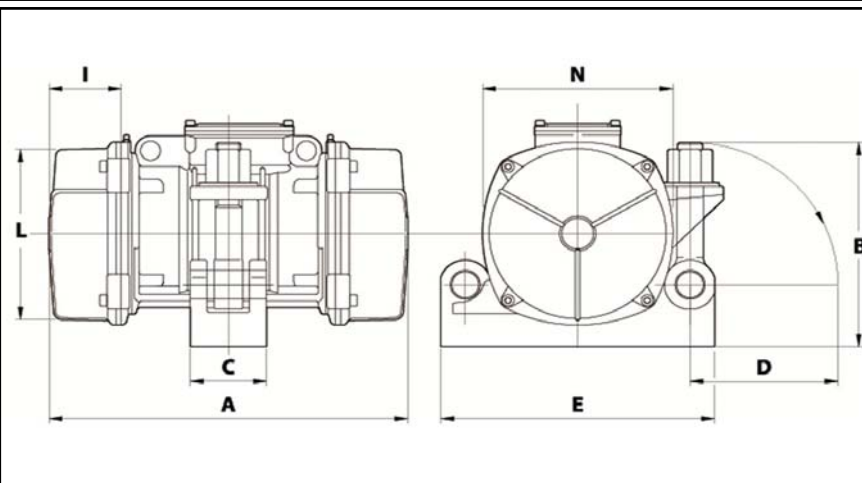

A	289
B	189
C	83
D	140
E	240
F	-
G	-
N° HOLES	-
H	-
I	63
L	170
M	-
N	182
