

ACBMV B. CASADIO VIBRATION
 Z.I. Mi-Plaine
 51 Rue Ampère
 B.P. 31
 69682 CHASSIEU CEDEX (FRANCE)
 Tel.: 04 78 90 87 87 / Fax.: 04 78 90 87 88
 Email: vibrateur@orange.fr
 Internet: acbmv.com

4 POLES - 1500 RPM ATEX II 2D tD A21 IP 66 ZONE 21-22
 REF.: 601381A Dust T°=135°C
 SIZE: 70

Certifications:



MECHANICAL AND ELECTRICAL SPECIFICATIONS

Eccentric weight setup (%)	Centrifugal force weight up/down (kg)	Static moment weight	Centrifugal force weight up/down (kN)	Static moment weight up (kgmm)	Estimated bearings life time (hours)
100	1908/707	280	18,72/6,94	757	3000
90	1717,2/636,3	252,00	16,85/6,25	681,30	4262
80	1526,4/565,6	224,00	14,98/5,55	605,60	6312
70	1335,6/494,9	196,00	13,10/4,86	529,90	9851
60	1144,8/424,2	168,00	11,23/4,16	454,20	16467
50	954/353,5	140,00	9,36/3,47	378,50	30238
40	763,2/282,8	112,00	7,49/2,78	302,80	63619
30	572,4/212,1	84,00	5,62/2,08	227,10	>100000
20	381,6/141,4	56,00	3,74/1,39	151,40	>100000
10	190,8/70,7	28,00	1,87/0,69	75,70	>100000

Power supply (volts)	400
Phases:	three phases
Frequency (Hz)	50 Hz
Rotation speed (RPM)	1500
Max input power (watt)	2200
Max current (amp)	3,9
IS/IR	7,11

DIMENSIONAL SPECIFICATIONS (mm)

Vibrator weight: 100 kg

Continual service ambient temperature: -20°C à +40°C - Tropicalization anti-mold - Mechanical protection: IP66 IK08 according to IEC

Bearing type: ROLLER

Lubrication LONG-LIFE with KLUEBER STABURAGS NBU 8EP.

Re lubrication quantity after 1000 hours of using: 52g

Max quantity by replaced bearing: 26g

Fixing with 6 screws M20 - 13/16" quality 8.8 with tightening torque (kgm - ft/lb): 38 - 275

Power supply cable size: 9 à 16 mm - Cable entry thread: M25x1,5

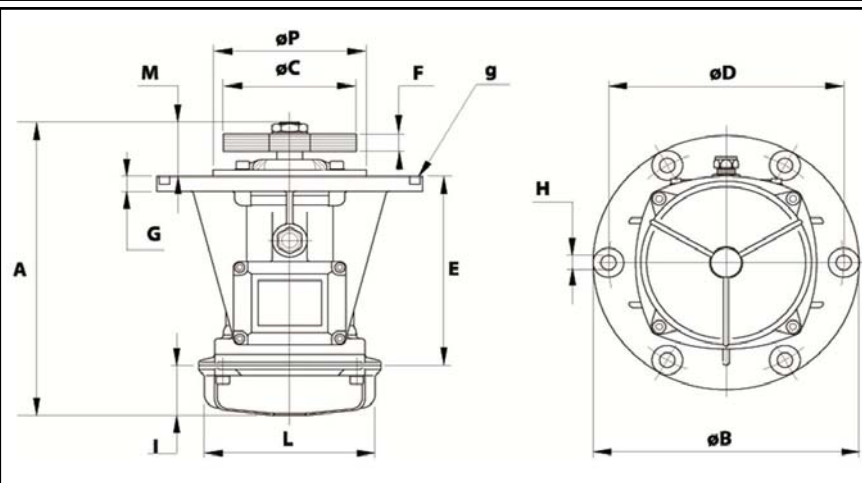

A	614
B	410
C	250 (50Hz) 244 (60Hz)
D	350
H	22
N° TROUS	6
E	310
F	78 (50Hz) 58 (60Hz)
G	20
I	178
L	280
M	125,5
P	234