

VIBRATOR TYPE: MTF 15/700-S02 260/460 VOLTS THREE PHASES 60 Hz

ACBMV B. CASADIO VIBRATION
 Z.I. Mi-Plaine
 51 Rue Ampère
 B.P. 31
 69682 CHASSIEU CEDEX (FRANCE)
 Tel.: 04 78 90 87 87 / Fax.: 04 78 90 87 88
 Email: vibrateur@orange.fr
 Internet: acbmv.com

4 POLES - 1800 RPM ATEX II 2D tD A21 IP 66 ZONE 21-22
 REF.: 601407C Dust T°=120°C
 SIZE: 30

Certifications:



MECHANICAL AND ELECTRICAL SPECIFICATIONS

Eccentric weight setup (%)	Centrifugal force weight up/down (kg)	Static moment weight	Centrifugal force weight up/down (kN)	Static moment weight up (kgmm)	Estimated bearings life time (hours)
100	380/380	105	3,73/3,73	105	11997
90	342/342	94,50	3,36/3,36	94,50	17045
80	304/304	84,00	2,98/2,98	84,00	25241
70	266/266	73,50	2,61/2,61	73,50	39392
60	228/228	63,00	2,24/2,24	63,00	65852
50	190/190	52,50	1,87/1,87	52,50	>100000
40	152/152	42,00	1,49/1,49	42,00	>100000
30	114/114	31,50	1,12/1,12	31,50	>100000
20	76/76	21,00	0,75/0,75	21,00	>100000
10	38/38	10,50	0,37/0,37	10,50	>100000

Power supply (volts)	460
Phases:	three phases
Frequency (Hz)	60 Hz
Rotation speed (RPM)	1800
Max input power (watt)	665
Max current (amp)	0,98
IS/IR	3,43

DIMENSIONAL SPECIFICATIONS (mm)

Vibrator weight: 24,5 kg

Continual service ambient temperature: -20°C à +40°C - Tropicalization anti-mold - Mechanical protection: IP66 IK08 according to IEC

Bearing type: ROLLER

Lubrication LONG-LIFE with KLUEBER STABURAGS NBU 8EP.

Re lubrication quantity after 1000 hours of using: 8g

Max quantity by replaced bearing: 4g

Fixing with 6 screws M10 - 7/16" quality 8.8 with tightening torque (kgm - ft/lb): 4.80 - 35

Power supply cable size: 9 à 16 mm - Cable entry thread: M25x1,5

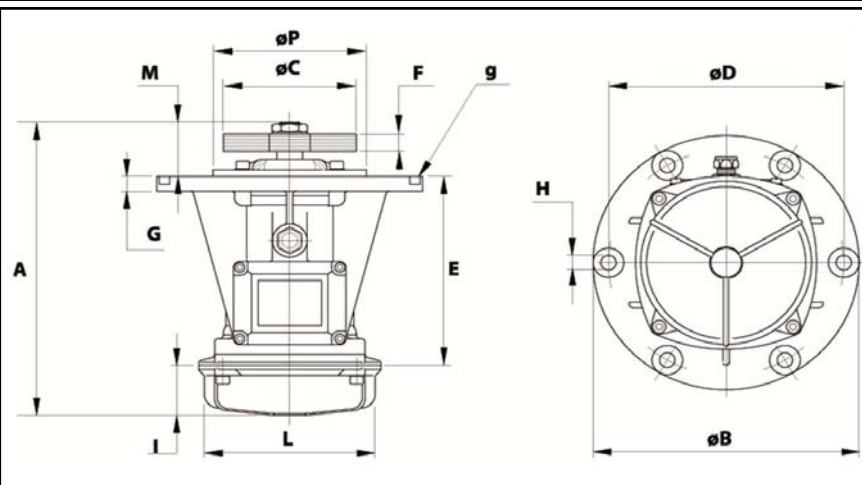

A	380,5
B	260
C	154
D	230
H	15
N° TROUS	6
E	182
F	59 (50Hz) 46 (60Hz)
G	15
I	106
L	170
M	92,5
P	150