

ACBMV B. CASADIO VIBRATION  
 Z.I. Mi-Plaine  
 51 Rue Ampère  
 B.P. 31  
 69682 CHASSIEU CEDEX (FRANCE)  
 Tel.: 04 78 90 87 87 / Fax.: 04 78 90 87 88  
 Email: [vibrateur@orange.fr](mailto:vibrateur@orange.fr)  
 Internet: [acbmv.com](http://acbmv.com)

4 POLES - 1800 RPM      ATEX II 2D tD A21 IP 66 ZONE 21-22  
 REF.: 601446C              Dust T°=120°C  
 SIZE: 01

Certifications:



### MECHANICAL AND ELECTRICAL SPECIFICATIONS

Eccentric weight setup (%)	Centrifugal force weight up/down (kg)	Static moment weight	Centrifugal force weight up/down (kN)	Static moment weight up (kgmm)	Estimated bearings life time (hours)
100	38/38	10,5	0,37/0,37	10,5	>100000
90	34,2/34,2	9,45	0,33/0,33	9,45	>100000
80	30,4/30,4	8,40	0,30/0,30	8,40	>100000
70	26,6/26,6	7,35	0,26/0,26	7,35	>100000
60	22,8/22,8	6,30	0,22/0,22	6,30	>100000
50	19/19	5,25	0,19/0,19	5,25	>100000
40	15,2/15,2	4,20	0,15/0,15	4,20	>100000
30	11,4/11,4	3,15	0,11/0,11	3,15	>100000
20	7,6/7,6	2,10	0,07/0,07	2,10	>100000
10	3,8/3,8	1,05	0,04/0,04	1,05	>100000

Power supply (volts)	460
Phases:	three phases
Frequency (Hz)	60 Hz
Rotation speed (RPM)	1800
Max input power (watt)	95
Max current (amp)	0,2
IS/IR	1,95

### DIMENSIONAL SPECIFICATIONS (mm)

**Vibrator weight: 6,5 kg**

Continual service ambient temperature: -20°C à +40°C - Tropicalization anti-mold - Mechanical protection: IP66 IK08 according to IEC

Bearing type: BALL

Lubrication "FOR LIFE" with double protection screen

Fixing with 4 screws M10 - 7/16" quality 8.8 with tightening torque (kgm - ft/lb): 4.80 - 35

Power supply cable size: 6.5 à 12 mm - Cable entry thread: M20x1,5

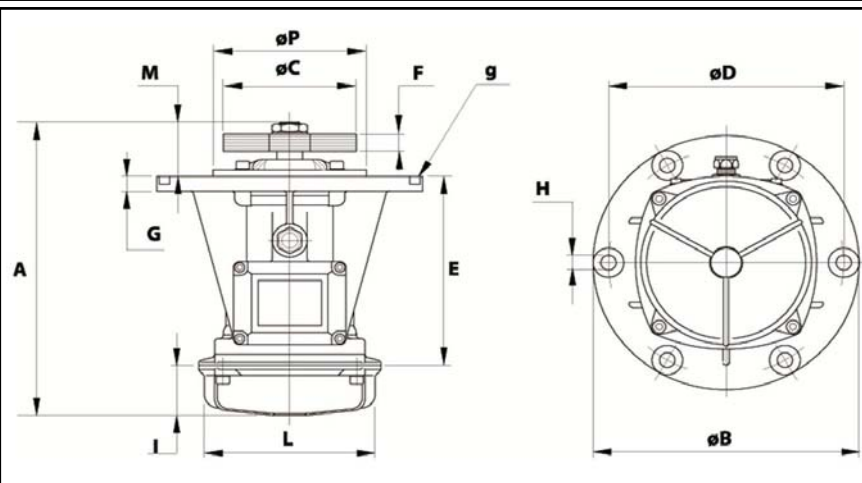

A	225,5
B	211,5
C	92
D	188
H	12
N° TROUS	4
E	144
F	31 (50Hz) 21 (60Hz)
G	10
I	58
L	103
M	23,5
P	-