

ACBMV B. CASADIO VIBRATION
 Z.I. Mi-Plaine
 51 Rue Ampère
 B.P. 31
 69682 CHASSIEU CEDEX (FRANCE)
 Tel.: 04 78 90 87 87 / Fax.: 04 78 90 87 88
 Email: vibrateur@orange.fr
 Internet: acbmv.com

6 POLES - 1200 RPM ATEX II 2D tD A21 IP 66 ZONE 21-22
 REF.: 602093C Dust T°=135°C
 SIZE: 95

Certifications:



MECHANICAL AND ELECTRICAL SPECIFICATIONS

Eccentric weight setup (%)	Static moment (kgmm)	Working moment (kgcm)	Centrifugal force (kg)	Centrifugal force (kN)	Estimated bearings life time (hours)
100	5385,00	1077,00	8669	85,00	15671
90	4846,50	969,30	7802	76,50	22266
80	4308,00	861,60	6935	68,00	32974
70	3769,50	753,90	6068	59,50	51465
60	3231,00	646,20	5201	51,00	86041
50	2692,50	538,50	4335	42,50	>100000
40	2154,00	430,80	3468	34,00	>100000
30	1615,50	323,10	2601	25,50	>100000
20	1077,00	215,40	1734	17,00	>100000
10	538,50	107,70	867	8,50	>100000

Power supply (volts)	460
Phases:	three phases
Frequency (Hz)	60 Hz
Rotation speed (RPM)	1200
Max input power (watt)	8200
Max current (amp)	12,90
IS/IR	4,88

DIMENSIONAL SPECIFICATIONS (mm)

Vibrator weight: 289,0 kg

Continual service ambient temperature: -20°C à +40°C - Tropicalization anti-mold - Mechanical protection: IP66 IK08 according to IEC

Bearing type: ROLLER

Lubrication LONG-LIFE with KLUEBER STABURAGS NBU 8EP.

Re lubrication quantity after 1000 hours of using: 80g

Max quantity by replaced bearing: 150g

Fixing with 4 screws M27 - 1" quality 8.8 with tightening torque (kgm - ft/lb): 89 - 645

Power supply cable size: 13 à 20 mm - Cable entry thread: M32x1,5

Maintenance space: 255 mm

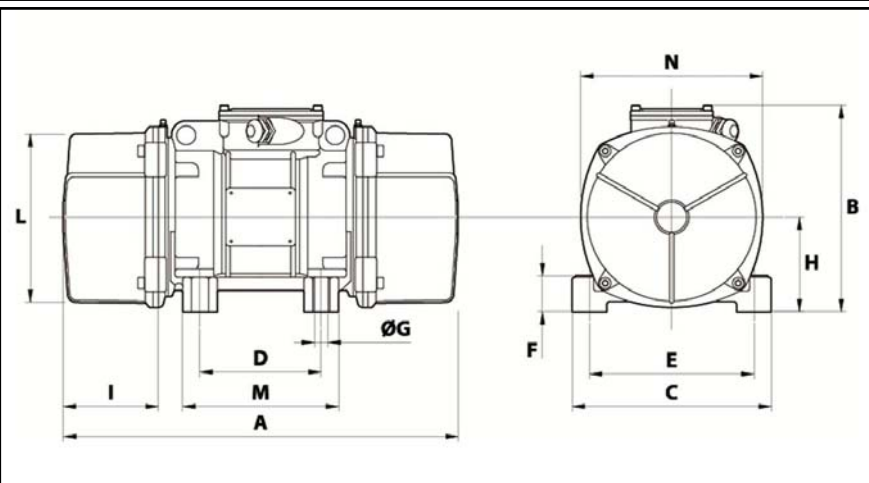

A	870
B	395
C	392
D	200
E	320
F	100
G	28
N° HOLES	4
H	192
I	255
L	355
M	270
N	375

--	--	--	--	--	--