

ACBMV B. CASADIO VIBRATION
 Z.I. Mi-Plaine
 51 Rue Ampère
 B.P. 31
 69682 CHASSIEU CEDEX (FRANCE)
 Tel.: 04 78 90 87 87 / Fax.: 04 78 90 87 88
 Email: vibrateur@orange.fr
 Internet: acbmv.com

6 POLES - 1200 RPM ATEX II 2D tD A21 IP 66 ZONE 21-22
 REF.: 602134C Dust T°=135°C
 SIZE: 100

Certifications:



MECHANICAL AND ELECTRICAL SPECIFICATIONS

Eccentric weight setup (%)	Static moment (kgmm)	Working moment (kgcm)	Centrifugal force (kg)	Centrifugal force (kN)	Estimated bearings life time (hours)
100	7543,00	1508,60	12141	119,00	18517
90	6788,70	1357,74	10927	107,10	26308
80	6034,40	1206,88	9713	95,20	38956
70	5280,10	1056,02	8499	83,30	60794
60	4525,80	905,16	7285	71,40	>100000
50	3771,50	754,30	6071	59,50	>100000
40	3017,20	603,44	4856	47,60	>100000
30	2262,90	452,58	3642	35,70	>100000
20	1508,60	301,72	2428	23,80	>100000
10	754,30	150,86	1214	11,90	>100000

Power supply (volts)	460
Phases:	three phases
Frequency (Hz)	60 Hz
Rotation speed (RPM)	1200
Max input power (watt)	9500
Max current (amp)	15,00
IS/IR	5,73

DIMENSIONAL SPECIFICATIONS (mm)

Vibrator weight: 445,0 kg

Continual service ambient temperature: -20°C à +40°C - Tropicalization anti-mold - Mechanical protection: IP66 IK08 according to IEC

Bearing type: ROLLER

Lubrication LONG-LIFE with KLUEBER STABURAGS NBU 8EP.

Re lubrication quantity after 1000 hours of using: 130g

Max quantity by replaced bearing: 260g

Fixing with 6 screws M42 - 1 5/8" quality 8.8 with tightening torque (kgm - ft/lb): 290 - 2090

Power supply cable size: 13 à 20 mm - Cable entry thread: M32x1,5

Maintenance space: 240 mm

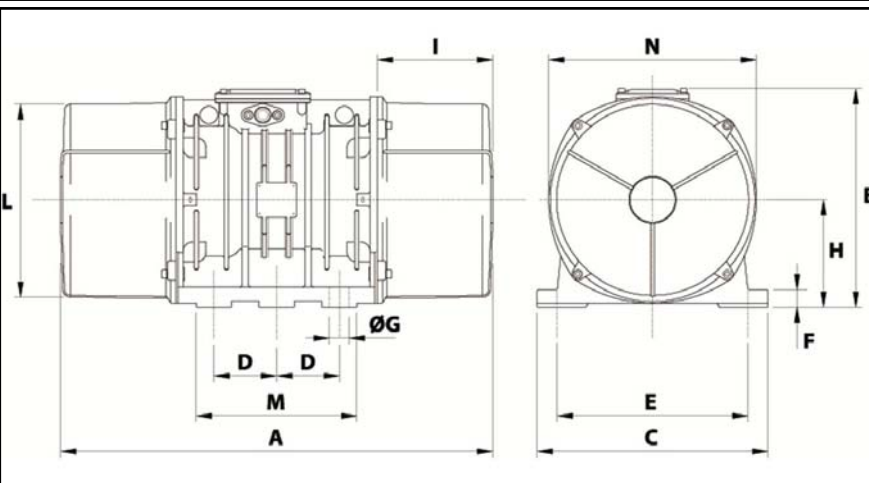

A	990
B	454
C	530
D	140
E	440
F	38
G	45
N° HOLES	6
H	230
I	240
L	423
M	370
N	448