

ACBMV B. CASADIO VIBRATION
 Z.I. Mi-Plaine
 51 Rue Ampère
 B.P. 31
 69682 CHASSIEU CEDEX (FRANCE)
 Tel.: 04 78 90 87 87 / Fax.: 04 78 90 87 88
 Email: vibrateur@orange.fr
 Internet: acbm.com

6 POLES - 1200 RPM
 REF.: 602274C
 SIZE: 50

Certifications:



MECHANICAL AND ELECTRICAL SPECIFICATIONS

Eccentric weight setup (%)	Static moment (kgmm)	Working moment (kgcm)	Centrifugal force (kg)	Centrifugal force (kN)	Estimated bearings life time (hours)
100	715	143,00	1151	11,30	42632
90	643,50	128,70	1036	10,17	60551
80	572,00	114,40	921	9,04	89630
70	500,50	100,10	806	7,91	>100000
60	429,00	85,80	691	6,78	>100000
50	357,50	71,50	576	5,65	>100000
40	286,00	57,20	460	4,52	>100000
30	214,50	42,90	345	3,39	>100000
20	143,00	28,60	230	2,26	>100000
10	71,50	14,30	115	1,13	>100000

Power supply (volts)	460
Phases:	three phases
Frequency (Hz)	60 Hz
Rotation speed (RPM)	1200
Max input power (watt)	Input: 870 Rating: 548
Max current (amp)	1,65
IS/IR	4,24

DIMENSIONAL SPECIFICATIONS (mm)

Vibrator weight: 72 kg

Continual service ambient temperature: -20°C à +40°C - Tropicalization anti-mold - Mechanical protection: IP66 IK08 according to IEC

Bearing type: ROLLER

Lubrication LONG-LIFE with KLUEBER STABURAGS NBU 8EP.

Re lubrication quantity after 1000 hours of using: 16g

Max quantity by replaced bearing: 30g

Fixing with 4 screws M20 - 13/16" quality 8.8 with tightening torque (kgm - ft/lb): 38 - 275

- Thread (pipe thread not supplied): NPT3/4"

Maintenance space: 171 (50Hz) 134 (60Hz) mm

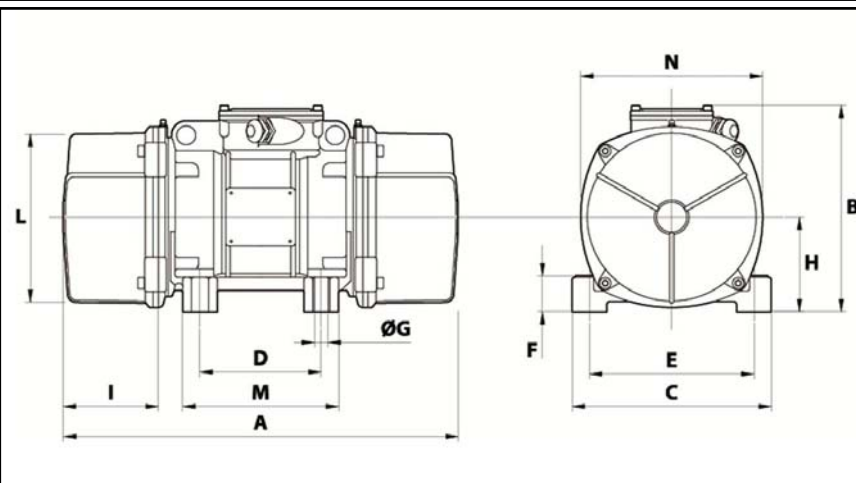

A	520
B	278,5
C	235
D	140
E	190
F	65
G	22
N° HOLES	4
H	116
I	134
L	210
M	185
N	225