

ACBMV B. CASADIO VIBRATION  
 Z.I. Mi-Plaine  
 51 Rue Ampère  
 B.P. 31  
 69682 CHASSIEU CEDEX (FRANCE)  
 Tel.: 04 78 90 87 87 / Fax.: 04 78 90 87 88  
 Email: [vibrateur@orange.fr](mailto:vibrateur@orange.fr)  
 Internet: [acbmv.com](http://acbmv.com)

6 POLES - 1000 RPM  
 REF.: 602319A  
 SIZE: 110

Certifications:



### MECHANICAL AND ELECTRICAL SPECIFICATIONS

Eccentric weight setup (%)	Static moment (kgmm)	Working moment (kgcm)	Centrifugal force (kg)	Centrifugal force (kN)	Estimated bearings life time (hours)
100	20025	4005,00	22386	220,00	13342
90	18022,50	3604,50	20147	198,00	18957
80	16020,00	3204,00	17909	176,00	28070
70	14017,50	2803,50	15670	154,00	43811
60	12015,00	2403,00	13432	132,00	73227
50	10012,50	2002,50	11193	110,00	>100000
40	8010,00	1602,00	8954	88,00	>100000
30	6007,50	1201,50	6716	66,00	>100000
20	4005,00	801,00	4477	44,00	>100000
10	2002,50	400,50	2239	22,00	>100000

Power supply (volts)	400
Phases:	three phases
Frequency (Hz)	50 Hz
Rotation speed (RPM)	1000
Max input power (watt)	19000
Max current (amp)	33
IS/IR	4,67

### DIMENSIONAL SPECIFICATIONS (mm)

**Vibrator weight: 933 kg**

Service continu temperature ambiante: -20°C à +40°C - Tropicalisation anti-moisissure - Protection mécanique: IP55 IK08 sec. IEC

Bearing type: ROLLER

Lubrication LONG-LIFE with KLUEBER STABURAGS NBU 8EP.

Re lubrication quantity after 1000 hours of using: 220g

Max quantity by replaced bearing: 400g

Fixing with 8 screws M42 - 1 5/8" quality 8.8 with tightening torque (kgm - ft/lb): 290 - 2090

Power supply cable size: 13 à 20 mm - Cable entry thread: M32x1,5

Maintenance space: 322,5 mm

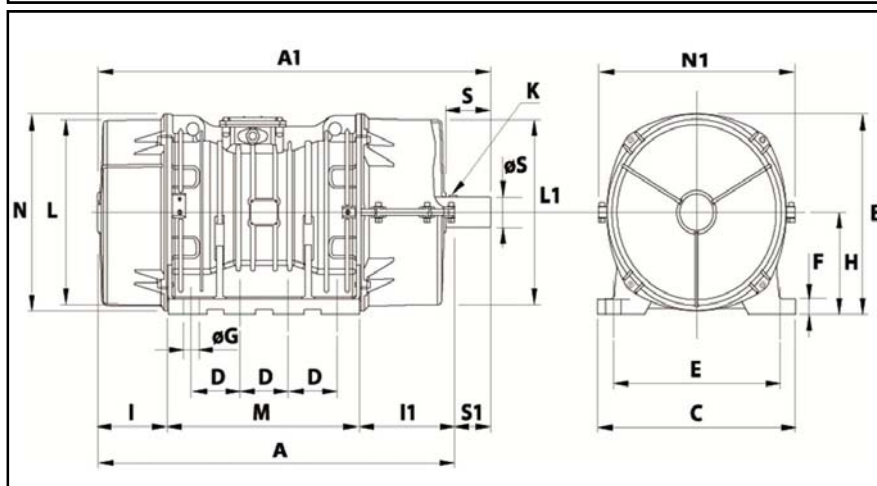

A	1175
B	607
C	610
D	140
E	520
F	38
G	45
N° HOLES	8
H	297
I	297,5
I1	322,5
N1	616
L	542
M	510
N	582

A1	L1	ØS	S	0	0
1234	546	105	90,5	59	0