

ACBMV B. CASADIO VIBRATION
 Z.I. Mi-Plaine
 51 Rue Ampère
 B.P. 31
 69682 CHASSIEU CEDEX (FRANCE)
 Tel.: 04 78 90 87 87 / Fax.: 04 78 90 87 88
 Email: vibrateur@orange.fr
 Internet: acbmv.com

6 POLES - 1000 RPM
 REF.: 602320A
 SIZE: 35

Certifications:

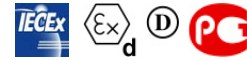

MECHANICAL AND ELECTRICAL SPECIFICATIONS

Eccentric weight setup (%)	Static moment (kgmm)	Working moment (kgcm)	Centrifugal force (kg)	Centrifugal force (kN)	Estimated bearings life time (hours)
100	457	91,40	512	5,02	>100000
90	411,30	82,26	461	4,52	>100000
80	365,60	73,12	410	4,02	>100000
70	319,90	63,98	358	3,51	>100000
60	274,20	54,84	307	3,01	>100000
50	228,50	45,70	256	2,51	>100000
40	182,80	36,56	205	2,01	>100000
30	137,10	27,42	154	1,51	>100000
20	91,40	18,28	102	1,00	>100000
10	45,70	9,14	51	0,50	>100000

Power supply (volts)	400
Phases:	three phases
Frequency (Hz)	50 Hz
Rotation speed (RPM)	1000
Max input power (watt)	Input: 300 Rating: 220
Max current (amp)	0,57
IS/IR	3,89

DIMENSIONAL SPECIFICATIONS (mm)

Vibrator weight: 47,5 kg

Continual service ambient temperature: -20°C à +40°C - Tropicalization anti-mold - Mechanical protection: IP66 IK08 according to IEC

Bearing type: ROLLER

Lubrication LONG-LIFE with KLUEBER STABURAGS NBU 8EP.

Re lubrication quantity after 1000 hours of using: 7g

Max quantity by replaced bearing: 12g

Fixing with 4 screws M16 - 5/8" quality 8.8 with tightening torque (kgm - ft/lb): 19 - 137

- Thread (pipe thread not supplied): NPT3/4"

Maintenance space: 118 mm

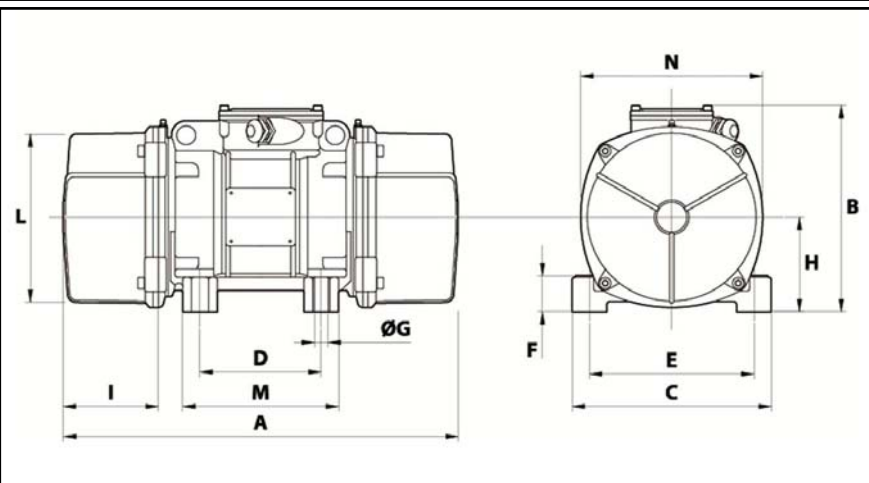

A	446
B	248,5
C	210
D	120
E	170
F	52
G	17
N° HOLES	4
H	112
I	118
L	192
M	160
N	218