

ACBMV B. CASADIO VIBRATION
 Z.I. Mi-Plaine
 51 Rue Ampère
 B.P. 31
 69682 CHASSIEU CEDEX (FRANCE)
 Tel.: 04 78 90 87 87 / Fax.: 04 78 90 87 88
 Email: vibrateur@orange.fr
 Internet: acbmv.com

6 POLES - 1000 RPM
 REF.: 602336A
 SIZE: 120

Certifications:



MECHANICAL AND ELECTRICAL SPECIFICATIONS

Eccentric weight setup (%)	Static moment (kgmm)	Working moment (kgcm)	Centrifugal force (kg)	Centrifugal force (kN)	Estimated bearings life time (hours)
100	27285,00	5457,00	30560	300,00	11190
90	24556,50	4911,30	27504	270,00	15898
80	21828,00	4365,60	24448	240,00	23543
70	19099,50	3819,90	21392	210,00	36743
60	16371,00	3274,20	18336	180,00	61422
50	13642,50	2728,50	15280	150,00	>100000
40	10914,00	2182,80	12224	120,00	>100000
30	8185,50	1637,10	9168	90,00	>100000
20	5457,00	1091,40	6112	60,00	>100000
10	2728,50	545,70	3056	30,00	>100000

Power supply (volts)	400
Phases:	three phases
Frequency (Hz)	50 Hz
Rotation speed (RPM)	1000
Max input power (watt)	24000
Max current (amp)	40,00
IS/IR	4,89

DIMENSIONAL SPECIFICATIONS (mm)

Vibrator weight: 1200,0 kg

Continual service ambient temperature: -20°C à +40°C - Tropicalization anti-mold - Mechanical protection: IP66 IK08 according to IEC

Bearing type: ROLLER

Lubrication LONG-LIFE with KLUEBER STABURAGS NBU 8EP.

Re lubrication quantity after 1000 hours of using: 260g

Max quantity by replaced bearing: 480g

Fixing with 8 screws M42 - 1 5/8" quality 8.8 with tightening torque (kgm - ft/lb): 290 - 2090

Power supply cable size: 13 à 20 mm - Cable entry thread: M32x1,5

Maintenance space: 310 mm

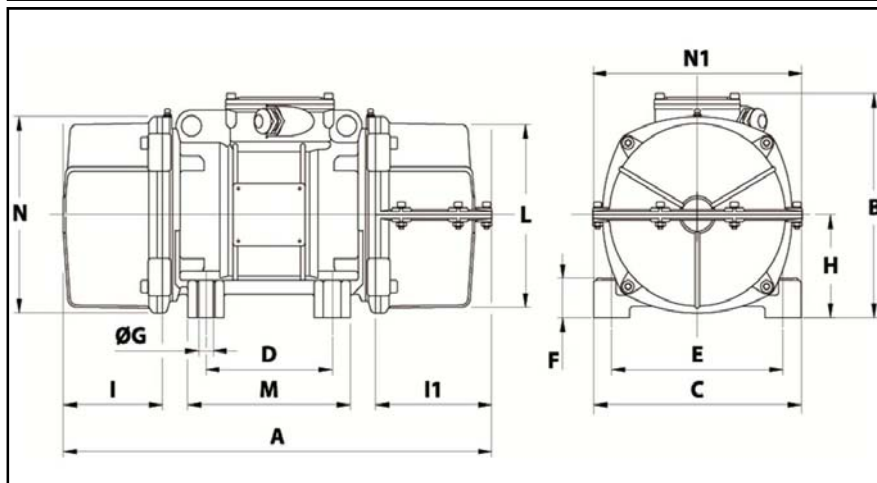

A	1205
B	648
C	700
D	140
E	600
F	45
G	45
N° HOLES	8
H	320
I	310
L	600
M	510
N	660