

ACBMV B. CASADIO VIBRATION  
 Z.I. Mi-Plaine  
 51 Rue Ampère  
 B.P. 31  
 69682 CHASSIEU CEDEX (FRANCE)  
 Tel.: 04 78 90 87 87 / Fax.: 04 78 90 87 88  
 Email: [vibrateur@orange.fr](mailto:vibrateur@orange.fr)  
 Internet: [acbmv.com](http://acbmv.com)

6 POLES - 1200 RPM  
 REF.: 602336C  
 SIZE: 120

Certifications:



### MECHANICAL AND ELECTRICAL SPECIFICATIONS

Eccentric weight setup (%)	Static moment (kgmm)	Working moment (kgcm)	Centrifugal force (kg)	Centrifugal force (kN)	Estimated bearings life time (hours)
100	18760,00	3752,00	30200	296,00	9640
90	16884,00	3376,80	27180	266,40	13696
80	15008,00	3001,60	24160	236,80	20282
70	13132,00	2626,40	21140	207,20	31653
60	11256,00	2251,20	18120	177,60	52914
50	9380,00	1876,00	15100	148,00	97165
40	7504,00	1500,80	12080	118,40	>100000
30	5628,00	1125,60	9060	88,80	>100000
20	3752,00	750,40	6040	59,20	>100000
10	1876,00	375,20	3020	29,60	>100000

Power supply (volts)	460
Phases:	three phases
Frequency (Hz)	60 Hz
Rotation speed (RPM)	1200
Max input power (watt)	25800
Max current (amp)	38,00
IS/IR	5,39

### DIMENSIONAL SPECIFICATIONS (mm)

**Vibrator weight: 1050,0 kg**

Continual service ambient temperature: -20°C à +40°C - Tropicalization anti-mold - Mechanical protection: IP66 IK08 according to IEC

Bearing type: ROLLER

Lubrication LONG-LIFE with KLUEBER STABURAGS NBU 8EP.

Re lubrication quantity after 1000 hours of using: 260g

Max quantity by replaced bearing: 480g

Fixing with 8 screws M42 - 1 5/8" quality 8.8 with tightening torque (kgm - ft/lb): 290 - 2090

Power supply cable size: 13 à 20 mm - Cable entry thread: M32x1,5

Maintenance space: 310 mm

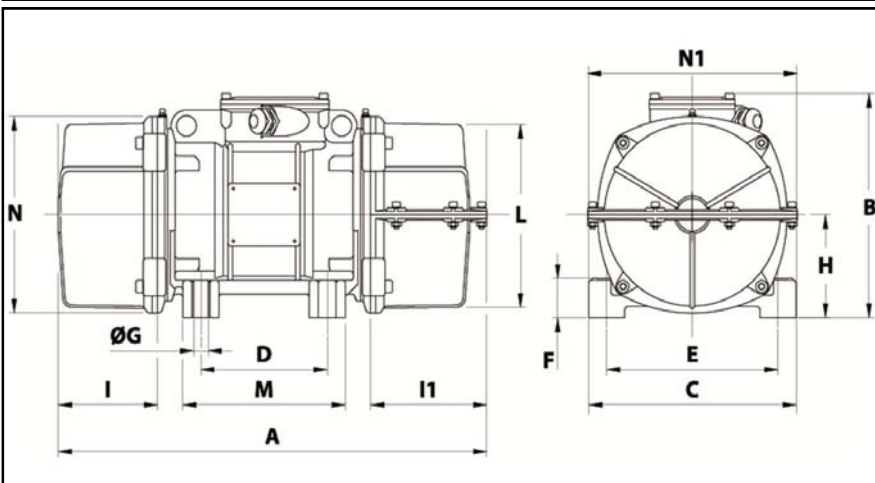

A	1205
B	648
C	700
D	140
E	600
F	45
G	45
N° HOLES	8
H	320
I	310
L	600
M	510
N	660