

ACBMV B. CASADIO VIBRATION
 Z.I. Mi-Plaine
 51 Rue Ampère
 B.P. 31
 69682 CHASSIEU CEDEX (FRANCE)
 Tel.: 04 78 90 87 87 / Fax.: 04 78 90 87 88
 Email: vibrateur@orange.fr
 Internet: acbmv.com

6 POLES - 1200 RPM ATEX II 2D tD A21 IP 66 ZONE 21-22
 REF.: 602349C Dust T°=135°C
 SIZE: 97

Certifications:



MECHANICAL AND ELECTRICAL SPECIFICATIONS

Eccentric weight setup (%)	Static moment (kgmm)	Working moment (kgcm)	Centrifugal force (kg)	Centrifugal force (kN)	Estimated bearings life time (hours)
100	6896,00	1379,20	11100	109,00	9414
90	6206,40	1241,28	9990	98,10	13375
80	5516,80	1103,36	8880	87,20	19806
70	4827,20	965,44	7770	76,30	30911
60	4137,60	827,52	6660	65,40	51674
50	3448,00	689,60	5550	54,50	94887
40	2758,40	551,68	4440	43,60	>100000
30	2068,80	413,76	3330	32,70	>100000
20	1379,20	275,84	2220	21,80	>100000
10	689,60	137,92	1110	10,90	>100000

Power supply (volts)	460
Phases:	three phases
Frequency (Hz)	60 Hz
Rotation speed (RPM)	1200
Max input power (watt)	8000
Max current (amp)	12,40
IS/IR	4,92

DIMENSIONAL SPECIFICATIONS (mm)

Vibrator weight: 370,0 kg

Continual service ambient temperature: -20°C à +40°C - Tropicalization anti-mold - Mechanical protection: IP66 IK08 according to IEC

Bearing type: ROLLER

Lubrication LONG-LIFE with KLUEBER STABURAGS NBU 8EP.

Re lubrication quantity after 1000 hours of using: 90g

Max quantity by replaced bearing: 180g

Fixing with 6 screws M36 - 1 3/8" quality 8.8 with tightening torque (kgm - ft/lb): 190 - 1370

Power supply cable size: 13 à 20 mm - Cable entry thread: M32x1,5

Maintenance space: 255 mm

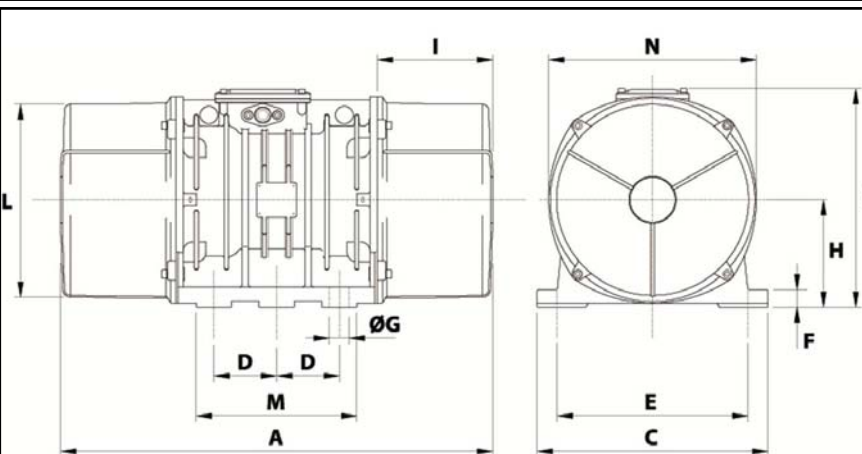

A	912
B	437
C	460
D	125
E	380
F	35
G	39
N° HOLES	6
H	215
I	255
L	387
M	320
N	414
