

ACBMV B. CASADIO VIBRATION  
 Z.I. Mi-Plaine  
 51 Rue Ampère  
 B.P. 31  
 69682 CHASSIEU CEDEX (FRANCE)  
 Tel.: 04 78 90 87 87 / Fax.: 04 78 90 87 88  
 Email: [vibrateur@orange.fr](mailto:vibrateur@orange.fr)  
 Internet: [acbmv.com](http://acbmv.com)

6 POLES - 1000 RPM  
 REF.: 602365A  
 SIZE: 80

Certifications:



### MECHANICAL AND ELECTRICAL SPECIFICATIONS

Eccentric weight setup (%)	Static moment (kgmm)	Working moment (kgcm)	Centrifugal force (kg)	Centrifugal force (kN)	Estimated bearings life time (hours)
100	3422	684,40	3826	37,50	13073
90	3079,80	615,96	3443	33,75	18581
80	2737,60	547,52	3061	30,00	27499
70	2395,40	479,08	2678	26,25	42936
60	2053,20	410,64	2296	22,50	71716
50	1711,00	342,20	1913	18,75	>100000
40	1368,80	273,76	1530	15,00	>100000
30	1026,60	205,32	1148	11,25	>100000
20	684,40	136,88	765	7,50	>100000
10	342,20	68,44	383	3,75	>100000

Power supply (volts)	400
Phases:	three phases
Frequency (Hz)	50 Hz
Rotation speed (RPM)	1000
Max input power (watt)	Input: 2100 Rating: 1700
Max current (amp)	4,75
IS/IR	4,19

### DIMENSIONAL SPECIFICATIONS (mm)

**Vibrator weight: 200 kg**

Continual service ambient temperature: -20°C à +40°C - Tropicalization anti-mold - Mechanical protection: IP66 IK08 according to IEC

Bearing type: ROLLER

Lubrication LONG-LIFE with KLUEBER STABURAGS NBU 8EP.

Re lubrication quantity after 1000 hours of using: 30g

Max quantity by replaced bearing: 60g

Fixing with 4 screws M24 - 15/16" quality 8.8 with tightening torque (kgm - ft/lb): 71 - 513

- Thread (pipe thread not supplied): NPT3/4"

Maintenance space: 202 mm

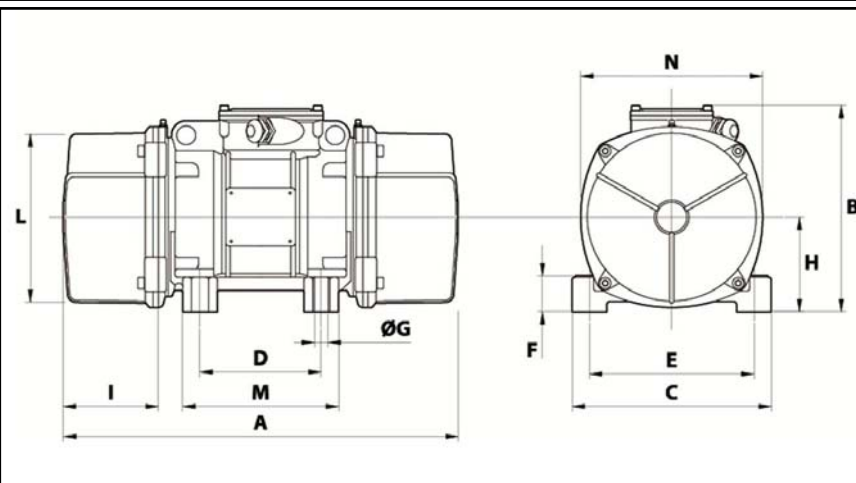

A	734
B	367
C	335
D	180
E	280
F	70
G	25
N° HOLES	4
H	175
I	202
L	303
M	235
N	320
