

ACBMV B. CASADIO VIBRATION  
 Z.I. Mi-Plaine  
 51 Rue Ampère  
 B.P. 31  
 69682 CHASSIEU CEDEX (FRANCE)  
 Tel.: 04 78 90 87 87 / Fax.: 04 78 90 87 88  
 Email: [vibrateur@orange.fr](mailto:vibrateur@orange.fr)  
 Internet: [acbm.com](http://acbm.com)

8 POLES - 750 RPM  
 REF.: 602513A  
 SIZE: 110  
 Certifications:



### MECHANICAL AND ELECTRICAL SPECIFICATIONS

Eccentric weight setup (%)	Static moment (kgmm)	Working moment (kgcm)	Centrifugal force (kg)	Centrifugal force (kN)	Estimated bearings life time (hours)
100	28633	5726,60	18005	177,00	22520
90	25769,70	5153,94	16205	159,30	31993
80	22906,40	4581,28	14404	141,60	47381
70	20043,10	4008,62	12604	123,90	73935
60	17179,80	3435,96	10803	106,20	>100000
50	14316,50	2863,30	9003	88,50	>100000
40	11453,20	2290,64	7202	70,80	>100000
30	8589,90	1717,98	5402	53,10	>100000
20	5726,60	1145,32	3601	35,40	>100000
10	2863,30	572,66	1801	17,70	>100000

Power supply (volts)	400
Phases:	three phases
Frequency (Hz)	50 Hz
Rotation speed (RPM)	750
Max input power (watt)	Input: 10000 Rating: 8100
Max current (amp)	21,4
IS/IR	6,97

### DIMENSIONAL SPECIFICATIONS (mm)

**Vibrator weight: 1015 kg**

Continual service ambient temperature: -20°C à +40°C - Tropicalization anti-mold - Mechanical protection: IP66 IK08 according to IEC

Bearing type: ROLLER

Lubrication LONG-LIFE with KLUEBER STABURAGS NBU 8EP.

Re lubrication quantity after 1000 hours of using: 220g

Max quantity by replaced bearing: 400g

Fixing with 8 screws M42 - 1 5/8" quality 8.8 with tightening torque (kgm - ft/lb): 290 - 2090

- Thread (pipe thread not supplied): NPT1"

Maintenance space: 297,5 mm

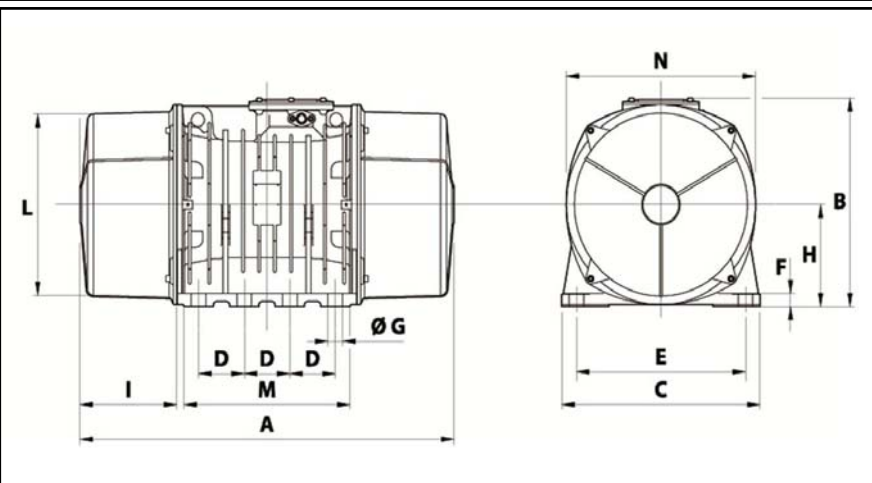

A	1150
B	607
C	610
D	140
E	520
F	38
G	45
N° HOLES	8
H	297
I	297.5
L	542
M	510
N	582

--	--	--	--	--	--