

ACBMV B. CASADIO VIBRATION
 Z.I. Mi-Plaine
 51 Rue Ampère
 B.P. 31
 69682 CHASSIEU CEDEX (FRANCE)
 Tel.: 04 78 90 87 87 / Fax.: 04 78 90 87 88
 Email: vibrateur@orange.fr
 Internet: acbmv.com

8 POLES - 900 RPM
 REF.: 602513C
 SIZE: 110

Certifications:



MECHANICAL AND ELECTRICAL SPECIFICATIONS

Eccentric weight setup (%)	Static moment (kgmm)	Working moment (kgcm)	Centrifugal force (kg)	Centrifugal force (kN)	Estimated bearings life time (hours)
100	24508	4901,60	22192	218,00	9347
90	22057,20	4411,44	19973	196,20	13280
80	19606,40	3921,28	17754	174,40	19664
70	17155,60	3431,12	15534	152,60	30694
60	14704,80	2940,96	13315	130,80	51309
50	12254,00	2450,80	11096	109,00	94212
40	9803,20	1960,64	8877	87,20	>100000
30	7352,40	1470,48	6658	65,40	>100000
20	4901,60	980,32	4438	43,60	>100000
10	2450,80	490,16	2219	21,80	>100000

Power supply (volts)	460
Phases:	three phases
Frequency (Hz)	60 Hz
Rotation speed (RPM)	900
Max input power (watt)	Input: 13000 Rating: 10300
Max current (amp)	22
IS/IR	5,5

DIMENSIONAL SPECIFICATIONS (mm)

Vibrator weight: 981 kg

Continual service ambient temperature: -20°C à +40°C - Tropicalization anti-mold - Mechanical protection: IP66 IK08 according to IEC

Bearing type: ROLLER

Lubrication LONG-LIFE with KLUEBER STABURAGS NBU 8EP.

Re lubrication quantity after 1000 hours of using: 220g

Max quantity by replaced bearing: 400g

Fixing with 8 screws M42 - 1 5/8" quality 8.8 with tightening torque (kgm - ft/lb): 290 - 2090

- Thread (pipe thread not supplied): NPT1"

Maintenance space: 297,5 mm

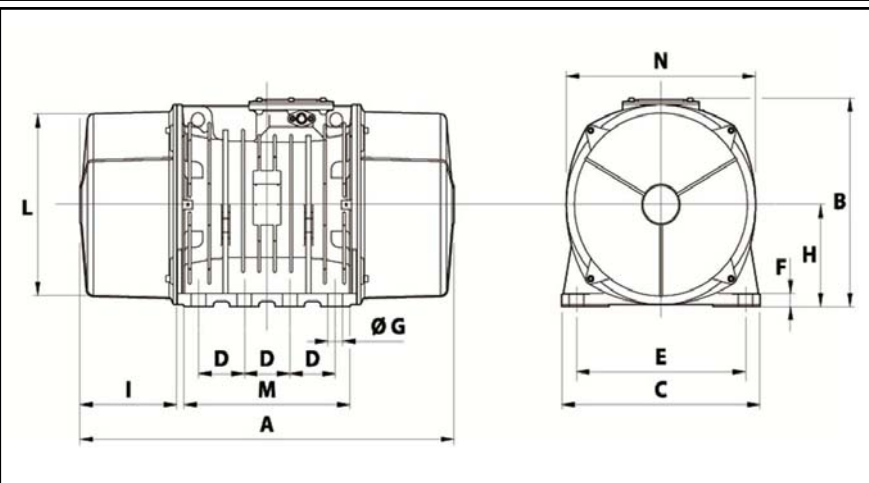

A	1150
B	607
C	610
D	140
E	520
F	38
G	45
N° HOLES	8
H	297
I	297.5
L	542
M	510
N	582
