

ACBMV B. CASADIO VIBRATION
 Z.I. Mi-Plaine
 51 Rue Ampère
 B.P. 31
 69682 CHASSIEU CEDEX (FRANCE)
 Tel.: 04 78 90 87 87 / Fax.: 04 78 90 87 88
 Email: vibrateur@orange.fr
 Internet: acbmv.com

8 POLES - 900 RPM
 REF.: 602577C
 SIZE: 30

Certifications:



MECHANICAL AND ELECTRICAL SPECIFICATIONS

Eccentric weight setup (%)	Static moment (kgmm)	Working moment (kgcm)	Centrifugal force (kg)	Centrifugal force (kN)	Estimated bearings life time (hours)
100	286	57,20	260	2,55	>100000
90	257,40	51,48	234	2,30	>100000
80	228,80	45,76	208	2,04	>100000
70	200,20	40,04	182	1,79	>100000
60	171,60	34,32	156	1,53	>100000
50	143,00	28,60	130	1,28	>100000
40	114,40	22,88	104	1,02	>100000
30	85,80	17,16	78	0,77	>100000
20	57,20	11,44	52	0,51	>100000
10	28,60	5,72	26	0,26	>100000

Power supply (volts)	460
Phases:	three phases
Frequency (Hz)	60 Hz
Rotation speed (RPM)	900
Max input power (watt)	Input: 380 Rating: 210
Max current (amp)	1,05
IS/IR	2,29

DIMENSIONAL SPECIFICATIONS (mm)

Vibrator weight: 30,3 kg

Continual service ambient temperature: -20°C à +40°C - Tropicalization anti-mold - Mechanical protection: IP66 IK08 according to IEC

Bearing type: BALL

Lubrication "FOR LIFE" with double protection screen

Fixing with 4 screws M16 - 5/8" quality 8.8 with tightening torque (kgm - ft/lb): 19 - 137

- Thread (pipe thread not supplied): NPT1/2"

Maintenance space: 106 mm

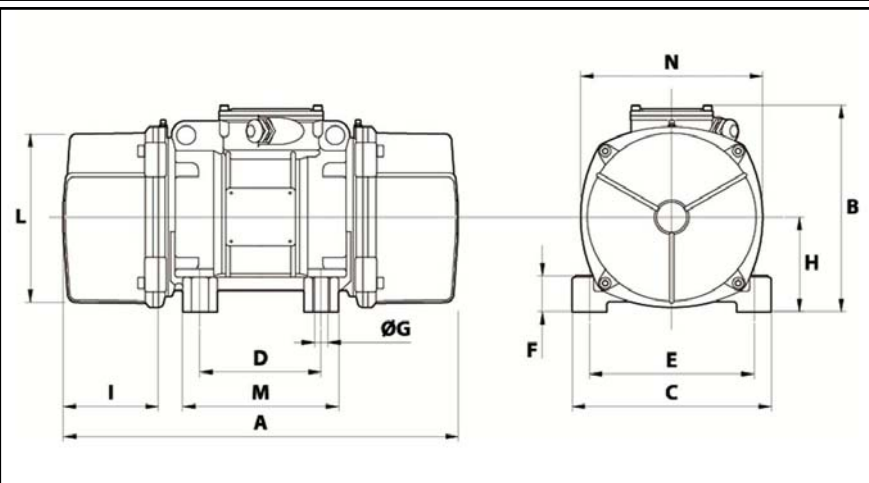

A	394
B	230,5
C	205
D	120
E	170
F	45
G	17
N° HOLES	4
H	102
I	106
L	177
M	162
N	200
