

ACBMV B. CASADIO VIBRATION
 Z.I. Mi-Plaine
 51 Rue Ampère
 B.P. 31
 69682 CHASSIEU CEDEX (FRANCE)
 Tel.: 04 78 90 87 87 / Fax.: 04 78 90 87 88
 Email: vibrateur@orange.fr
 Internet: acbm.com

8 POLES - 900 RPM
 REF.: 602581C
 SIZE: 40

Certifications:

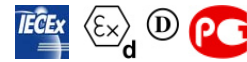

MECHANICAL AND ELECTRICAL SPECIFICATIONS

Eccentric weight setup (%)	Static moment (kgmm)	Working moment (kgcm)	Centrifugal force (kg)	Centrifugal force (kN)	Estimated bearings life time (hours)
100	723	144,60	656	6,44	>100000
90	650,70	130,14	590	5,80	>100000
80	578,40	115,68	525	5,15	>100000
70	506,10	101,22	459	4,51	>100000
60	433,80	86,76	394	3,86	>100000
50	361,50	72,30	328	3,22	>100000
40	289,20	57,84	262	2,58	>100000
30	216,90	43,38	197	1,93	>100000
20	144,60	28,92	131	1,29	>100000
10	72,30	14,46	66	0,64	>100000

Power supply (volts)	460
Phases:	three phases
Frequency (Hz)	60 Hz
Rotation speed (RPM)	900
Max input power (watt)	Input: 340 Rating: 184
Max current (amp)	0,9
IS/IR	3,11

DIMENSIONAL SPECIFICATIONS (mm)

Vibrator weight: 70,7 kg

Continual service ambient temperature: -20°C à +40°C - Tropicalization anti-mold - Mechanical protection: IP66 IK08 according to IEC

Bearing type: ROLLER

Lubrication LONG-LIFE with KLUEBER STABURAGS NBU 8EP.

Re lubrication quantity after 1000 hours of using: 16g

Max quantity by replaced bearing: 30g

Fixing with 4 screws M16 - 5/8" quality 8.8 with tightening torque (kgm - ft/lb): 19 - 137

- Thread (pipe thread not supplied): NPT3/4"

Maintenance space: 134 mm

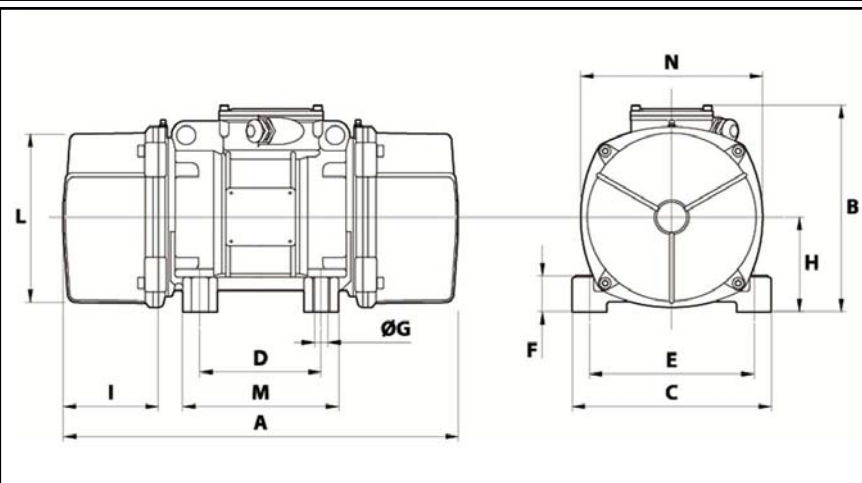

A	520
B	278,5
C	235
D	140
E	190
F	65
G	17
N° HOLES	4
H	116
I	134
L	210
M	185
N	225