

VIBRATOR TYPE: MVS1 3/500E-S02 230/400 VOLTS THREE PHASES 50 Hz

ACBMV B. CASADIO VIBRATION
 Z.I. Mi-Plaine
 51 Rue Ampère
 B.P. 31
 69682 CHASSIEU CEDEX (FRANCE)
 Tel.: 04 78 90 87 87 / Fax.: 04 78 90 87 88
 Email: vibrateur@orange.fr
 Internet: acbm.com

2 POLES - 3000 RPM ATEX II 2G,D - Classe Ex e II T4/T3 tD A21 IP 66 ZONE 1-2 / 21-22
 REF.: 6E0314A Gas T°=T3-T4 Dust T°=120°C
 SIZE: 20

Certifications:



MECHANICAL AND ELECTRICAL SPECIFICATIONS

Eccentric weight setup (%)	Static moment (kgmm)	Working moment (kgcm)	Centrifugal force (kg)	Centrifugal force (kN)	Estimated bearings life time (hours)
100	49,90	9,98	503	4,93	4375
90	44,91	8,98	453	4,44	5989
80	39,92	7,98	402	3,94	8570
70	34,93	6,99	352	3,45	12766
60	29,94	5,99	302	2,96	20214
50	24,95	4,99	252	2,47	34792
40	19,96	3,99	201	1,97	68564
30	14,97	2,99	151	1,48	>100000
20	9,98	2,00	101	0,99	>100000
10	4,99	1,00	50	0,49	>100000

Power supply (volts)	400
Phases:	three phases
Frequency (Hz)	50 Hz
Rotation speed (RPM)	3000
Max input power (watt)	Input: T3=500 T4=350 Rating: T3=300 T4=210
Max current (amp)	T3=0,76 T4=0,57
IS/IR	T3=4,2 T4=5,6

DIMENSIONAL SPECIFICATIONS (mm)

Vibrator weight: 14,8 kg

Continual service ambient temperature: -20°C à +40°C - Tropicalization anti-mold - Mechanical protection: IP66 IK08 according to IEC

Bearing type: BALL

Lubrication "FOR LIFE" with double protection screen

Fixing with 4 screws M12 - 1/2" quality 8.8 with tightening torque (kgm - ft/lb): 8 - 58

Power supply cable size: 9 à 16 mm - Cable entry thread: M25x1,5

Maintenance space: 65 mm

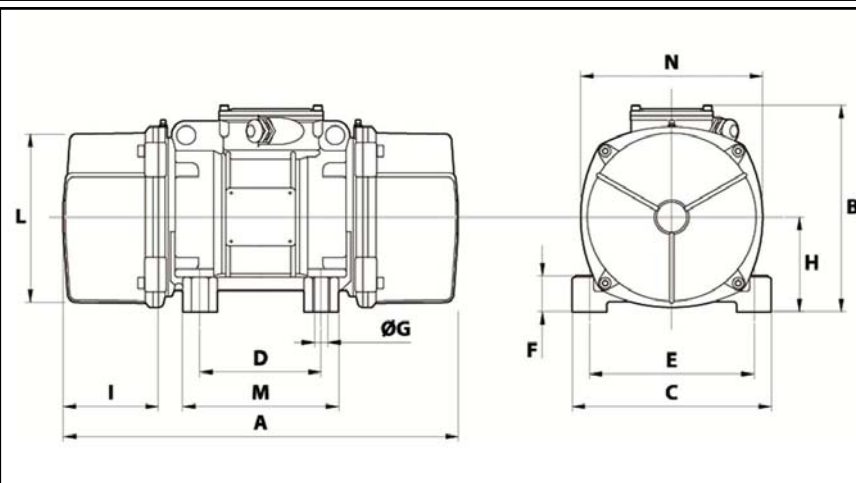

A	288
B	203
C	167
D	105
E	140
F	30
G	13
N° HOLES	4
H	30
I	65
L	145
M	140
N	160