

ACBMV B. CASADIO VIBRATION
 Z.I. Mi-Plaine
 51 Rue Ampère
 B.P. 31
 69682 CHASSIEU CEDEX (FRANCE)
 Tel.: 04 78 90 87 87 / Fax.: 04 78 90 87 88
 Email: vibrateur@orange.fr
 Internet: acbmv.com

2 POLES - 3600 RPM
 REF.: 600328C
 SIZE: 00

Certifications:



MECHANICAL AND ELECTRICAL SPECIFICATIONS

Eccentric weight setup (%)	Static moment (kgmm)	Working moment (kgcm)	Centrifugal force (kg)	Centrifugal force (kN)	Estimated bearings life time (hours)
100	12	2,40	174	1,71	5625
90	10,80	2,16	157	1,54	7657
80	9,60	1,92	139	1,37	11034
70	8,40	1,68	122	1,20	16319
60	7,20	1,44	104	1,03	26343
50	6,00	1,20	87	0,86	45000
40	4,80	0,96	70	0,68	86393
30	3,60	0,72	52	0,51	>100000
20	2,40	0,48	35	0,34	>100000
10	1,20	0,24	17	0,17	>100000

Power supply (volts)	260
Phases:	single phase
Frequency (Hz)	60 Hz
Rotation speed (RPM)	3600
Max input power (watt)	165
Max current (amp)	1,52
IS/IR	2,24

DIMENSIONAL SPECIFICATIONS (mm)

Vibrator weight: 7,8 kg

Continual service ambient temperature: -20°C à +40°C - Tropicalization anti-mold - Mechanical protection: IP66 IK08 according to IEC

Bearing type: BALL

Lubrication "FOR LIFE" with double protection screen

Fixing with 4 screws M8 - 5/16" quality 8.8 with tightening torque (kgm - ft/lb): 2.30 - 16.50

Power supply cable size: 6.5 à 12 mm - Cable entry thread: M20x1,5

Maintenance space: 45 mm

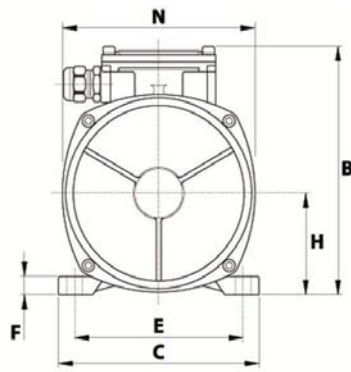
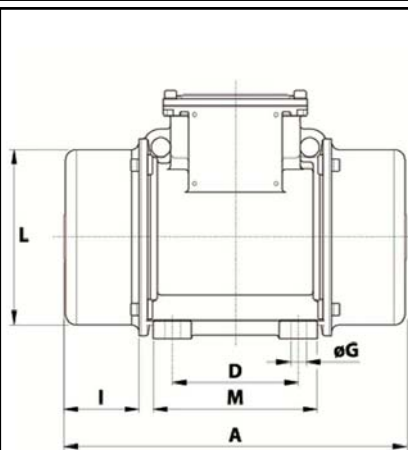

A	209
B	151
C	125
D	62-74**
E	106
F	10
G	9
N° HOLES	4
H	61
I	45
L	100
M	102
N	117

**					
Slot					