

ACBMV B. CASADIO VIBRATION  
 Z.I. Mi-Plaine  
 51 Rue Ampère  
 B.P. 31  
 69682 CHASSIEU CEDEX (FRANCE)  
 Tel.: 04 78 90 87 87 / Fax.: 04 78 90 87 88  
 Email: [vibrateur@orange.fr](mailto:vibrateur@orange.fr)  
 Internet: [acbm.com](http://acbm.com)

2 POLES - 3000 RPM  
 REF.: 600330A  
 SIZE: 10

Certifications:



### MECHANICAL AND ELECTRICAL SPECIFICATIONS

Eccentric weight setup (%)	Static moment (kgmm)	Working moment (kgcm)	Centrifugal force (kg)	Centrifugal force (kN)	Estimated bearings life time (hours)
100	30,1	6,02	304	2,98	3623
90	27,09	5,42	274	2,68	4948
80	24,08	4,82	243	2,38	7094
70	21,07	4,21	213	2,09	10533
60	18,06	3,61	182	1,79	16884
50	15,05	3,01	152	1,49	28984
40	12,04	2,41	122	1,19	56054
30	9,03	1,81	91	0,89	>100000
20	6,02	1,20	61	0,60	>100000
10	3,01	0,60	30	0,30	>100000

Power supply (volts)	400
Phases:	three phases
Frequency (Hz)	50 Hz
Rotation speed (RPM)	3000
Max input power (watt)	260
Max current (amp)	0,6
IS/IR	4,2

### DIMENSIONAL SPECIFICATIONS (mm)

**Vibrator weight: 12,5 kg**

Continual service ambient temperature: -20°C à +40°C - Tropicalization anti-mold - Mechanical protection: IP66 IK08 according to IEC

Bearing type: BALL

Lubrication "FOR LIFE" with double protection screen

Fixing with 4 screws M12 - 1/2" quality 8.8 with tightening torque (kgm - ft/lb): 8 - 58

Power supply cable size: 6.5 à 12 mm - Cable entry thread: M20x1,5

Maintenance space: 54 mm

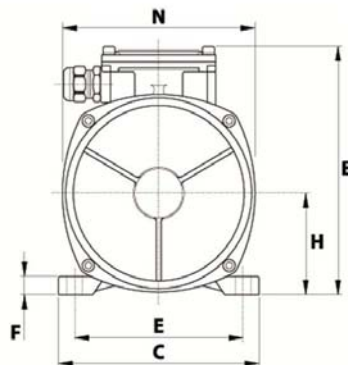
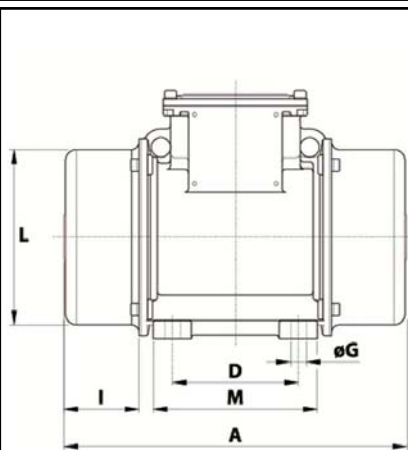

A	255
B	176
C	152
D	90
E	125
F	12
G	13
N° HOLES	4
H	73
I	54
L	124
M	122
N	141
