

ACBMV B. CASADIO VIBRATION
 Z.I. Mi-Plaine
 51 Rue Ampère
 B.P. 31
 69682 CHASSIEU CEDEX (FRANCE)
 Tel.: 04 78 90 87 87 / Fax.: 04 78 90 87 88
 Email: vibrateur@orange.fr
 Internet: acbmv.com

2 POLES - 3600 RPM
 REF.: 600331C
 SIZE: 20

Certifications:



MECHANICAL AND ELECTRICAL SPECIFICATIONS

Eccentric weight setup (%)	Static moment (kgmm)	Working moment (kgcm)	Centrifugal force (kg)	Centrifugal force (kN)	Estimated bearings life time (hours)
100	32,4	6,48	471	4,62	4469
90	29,16	5,83	424	4,16	6126
80	25,92	5,18	377	3,70	8715
70	22,68	4,54	330	3,23	12994
60	19,44	3,89	283	2,77	20602
50	16,20	3,24	236	2,31	35525
40	12,96	2,59	188	1,85	70275
30	9,72	1,94	141	1,39	>100000
20	6,48	1,30	94	0,92	>100000
10	3,24	0,65	47	0,46	>100000

Power supply (volts)	260
Phases:	single phase
Frequency (Hz)	60 Hz
Rotation speed (RPM)	3600
Max input power (watt)	500
Max current (amp)	4,5
IS/IR	4,22

DIMENSIONAL SPECIFICATIONS (mm)

Vibrator weight: 17,5 kg

Continual service ambient temperature: -20°C à +40°C - Tropicalization anti-mold - Mechanical protection: IP66 IK08 according to IEC

Bearing type: BALL

Lubrication "FOR LIFE" with double protection screen

Fixing with 4 screws M12 - 1/2" quality 8.8 with tightening torque (kgm - ft/lb): 8 - 58

Power supply cable size: 9 à 16 mm - Cable entry thread: M25x1,5

Maintenance space: 63 mm

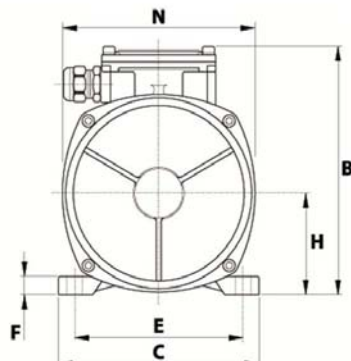

A	284
B	200
C	167
D	105
E	140
F	15
G	13
N° HOLES	4
H	82,5
I	63
L	143
M	137
N	160

--	--	--	--	--	--