

ACBMV B. CASADIO VIBRATION
 Z.I. Mi-Plaine
 51 Rue Ampère
 B.P. 31
 69682 CHASSIEU CEDEX (FRANCE)
 Tel.: 04 78 90 87 87 / Fax.: 04 78 90 87 88
 Email: vibrateur@orange.fr
 Internet: acbmv.com

2 POLES - 3000 RPM
 REF.: 600333A
 SIZE: 35

Certifications:



MECHANICAL AND ELECTRICAL SPECIFICATIONS

Eccentric weight setup (%)	Static moment (kgmm)	Working moment (kgcm)	Centrifugal force (kg)	Centrifugal force (kN)	Estimated bearings life time (hours)
100	110	22,00	1105	10,80	6452
90	99,00	19,80	995	9,72	9151
80	88,00	17,60	884	8,64	13575
70	77,00	15,40	774	7,56	21140
60	66,00	13,20	663	6,48	35415
50	55,00	11,00	553	5,40	64836
40	44,00	8,80	442	4,32	>100000
30	33,00	6,60	332	3,24	>100000
20	22,00	4,40	221	2,16	>100000
10	11,00	2,20	111	1,08	>100000

Power supply (volts)	400
Phases:	three phases
Frequency (Hz)	50 Hz
Rotation speed (RPM)	3000
Max input power (watt)	1000
Max current (amp)	1,75
IS/IR	4

DIMENSIONAL SPECIFICATIONS (mm)

Vibrator weight: 30 kg

Continual service ambient temperature: -20°C à +40°C - Tropicalization anti-mold - Mechanical protection: IP66 IK08 according to IEC

Bearing type: ROLLER

Lubrication LONG-LIFE with KLUEBER ISOFLEX NBU 15.

Re lubrication quantity after 1000 hours of using: 7g

Max quantity by replaced bearing: 12g

Fixing with 4 screws M16 - 5/8" quality 8.8 with tightening torque (kgm - ft/lb): 19 - 137

Power supply cable size: 9 à 16 mm - Cable entry thread: M25x1,5

Maintenance space: 77 mm

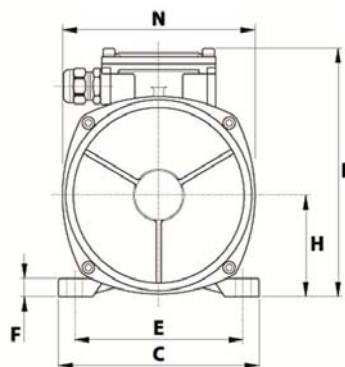
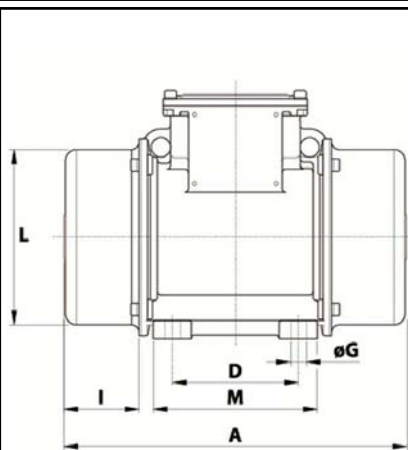

A	354
B	232
C	205
D	120
E	170
F	20
G	17
N° HOLES	4
H	104,5
I	77
L	181
M	162
N	203
