

ACBMV B. CASADIO VIBRATION
 Z.I. Mi-Plaine
 51 Rue Ampère
 B.P. 31
 69682 CHASSIEU CEDEX (FRANCE)
 Tel.: 04 78 90 87 87 / Fax.: 04 78 90 87 88
 Email: vibrateur@orange.fr
 Internet: acbmv.com

2 POLES - 3600 RPM
 REF.: 600333C
 SIZE: 35

Certifications:



MECHANICAL AND ELECTRICAL SPECIFICATIONS

Eccentric weight setup (%)	Static moment (kgmm)	Working moment (kgcm)	Centrifugal force (kg)	Centrifugal force (kN)	Estimated bearings life time (hours)
100	73	14,60	1061	10,40	6157
90	65,70	13,14	955	9,36	8745
80	58,40	11,68	849	8,32	12944
70	51,10	10,22	743	7,28	20189
60	43,80	8,76	637	6,24	33725
50	36,50	7,30	531	5,20	61864
40	29,20	5,84	424	4,16	>100000
30	21,90	4,38	318	3,12	>100000
20	14,60	2,92	212	2,08	>100000
10	7,30	1,46	106	1,04	>100000

Power supply (volts)	460
Phases:	three phases
Frequency (Hz)	60 Hz
Rotation speed (RPM)	3600
Max input power (watt)	1200
Max current (amp)	1,75
IS/IR	4

DIMENSIONAL SPECIFICATIONS (mm)

Vibrator weight: 29 kg

Continual service ambient temperature: -20°C à +40°C - Tropicalization anti-mold - Mechanical protection: IP66 IK08 according to IEC

Bearing type: ROLLER

Lubrication LONG-LIFE with KLUEBER ISOFLEX NBU 15.

Re lubrication quantity after 1000 hours of using: 7g

Max quantity by replaced bearing: 12g

Fixing with 4 screws M16 - 5/8" quality 8.8 with tightening torque (kgm - ft/lb): 19 - 137

Power supply cable size: 9 à 16 mm - Cable entry thread: M25x1,5

Maintenance space: 77 mm

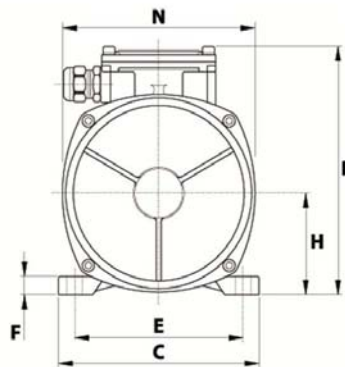
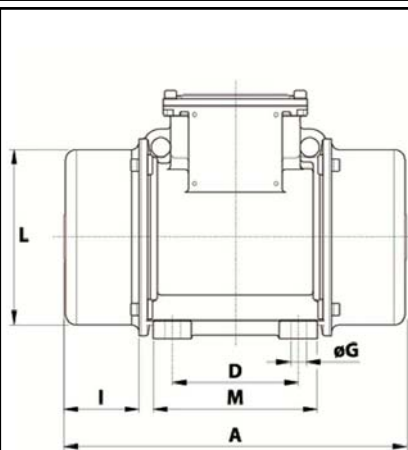

A	354
B	232
C	205
D	120
E	170
F	20
G	17
N° HOLES	4
H	104,5
I	77
L	181
M	162
N	203