

ACBMV B. CASADIO VIBRATION
 Z.I. Mi-Plaine
 51 Rue Ampère
 B.P. 31
 69682 CHASSIEU CEDEX (FRANCE)
 Tel.: 04 78 90 87 87 / Fax.: 04 78 90 87 88
 Email: vibrateur@orange.fr
 Internet: acbmv.com

2 POLES - 3000 RPM
 REF.: 600334A
 SIZE: 40

Certifications:



MECHANICAL AND ELECTRICAL SPECIFICATIONS

Eccentric weight setup (%)	Static moment (kgmm)	Working moment (kgcm)	Centrifugal force (kg)	Centrifugal force (kN)	Estimated bearings life time (hours)
100	153	30,60	1545	15,20	2656
90	137,70	27,54	1391	13,68	3769
80	122,40	24,48	1236	12,16	5588
70	107,10	21,42	1082	10,64	8708
60	91,80	18,36	927	9,12	14579
50	76,50	15,30	773	7,60	26713
40	61,20	12,24	618	6,08	56324
30	45,90	9,18	464	4,56	>100000
20	30,60	6,12	309	3,04	>100000
10	15,30	3,06	155	1,52	>100000

Power supply (volts)	400
Phases:	three phases
Frequency (Hz)	50 Hz
Rotation speed (RPM)	3000
Max input power (watt)	1400
Max current (amp)	2,3
IS/IR	6,12

DIMENSIONAL SPECIFICATIONS (mm)

Vibrator weight: 39,6 kg

Continual service ambient temperature: -20°C à +40°C - Tropicalization anti-mold - Mechanical protection: IP66 IK08 according to IEC

Bearing type: ROLLER

Lubrication LONG-LIFE with KLUEBER ISOFLEX NBU 15.

Re lubrication quantity after 1000 hours of using: 9g

Max quantity by replaced bearing: 16g

Fixing with 4 screws M16 - 5/8" quality 8.8 with tightening torque (kgm - ft/lb): 19 - 137

Power supply cable size: 9 à 16 mm - Cable entry thread: M25x1,5

Maintenance space: 103 mm

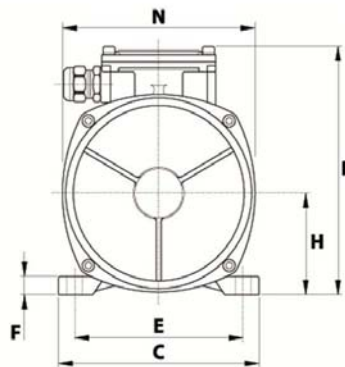
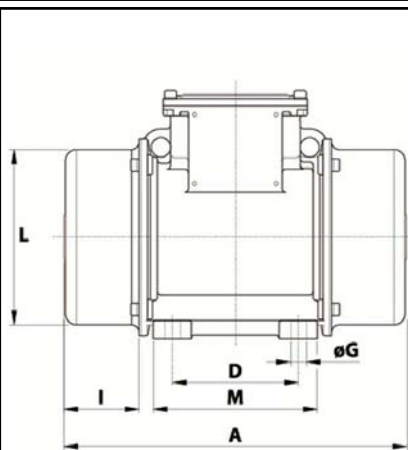

A	438
B	245
C	230
D	140
E	190
F	25
G	17
N° HOLES	4
H	116
I	103
L	201
M	180
N	225
