

ACBMV B. CASADIO VIBRATION  
 Z.I. Mi-Plaine  
 51 Rue Ampère  
 B.P. 31  
 69682 CHASSIEU CEDEX (FRANCE)  
 Tel.: 04 78 90 87 87 / Fax.: 04 78 90 87 88  
 Email: [vibrateur@orange.fr](mailto:vibrateur@orange.fr)  
 Internet: [acbmv.com](http://acbmv.com)

2 POLES - 3000 RPM  
 REF.: 600335A  
 SIZE: 50

Certifications:



### MECHANICAL AND ELECTRICAL SPECIFICATIONS

Eccentric weight setup (%)	Static moment (kgmm)	Working moment (kgcm)	Centrifugal force (kg)	Centrifugal force (kN)	Estimated bearings life time (hours)
100	205	41,00	2059	20,20	11310
90	184,50	36,90	1853	18,18	16072
80	164,00	32,80	1647	16,16	23805
70	143,50	28,70	1441	14,14	37162
60	123,00	24,60	1235	12,12	62148
50	102,50	20,50	1030	10,10	>100000
40	82,00	16,40	824	8,08	>100000
30	61,50	12,30	618	6,06	>100000
20	41,00	8,20	412	4,04	>100000
10	20,50	4,10	206	2,02	>100000

Power supply (volts)	400
Phases:	three phases
Frequency (Hz)	50 Hz
Rotation speed (RPM)	3000
Max input power (watt)	2200
Max current (amp)	3,5
IS/IR	6

### DIMENSIONAL SPECIFICATIONS (mm)

**Vibrator weight: 48,7 kg**

Continual service ambient temperature: -20°C à +40°C - Tropicalization anti-mold - Mechanical protection: IP66 IK08 according to IEC

Bearing type: ROLLER

Lubrication LONG-LIFE with KLUEBER ISOFLEX NBU 15.

Re lubrication quantity after 1000 hours of using: 16g

Max quantity by replaced bearing: 30g

Fixing with 4 screws M16 - 5/8" quality 8.8 with tightening torque (kgm - ft/lb): 19 - 137

Power supply cable size: 9 à 16 mm - Cable entry thread: M25x1,5

Maintenance space: 103 mm

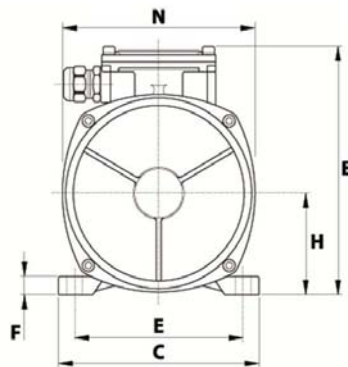
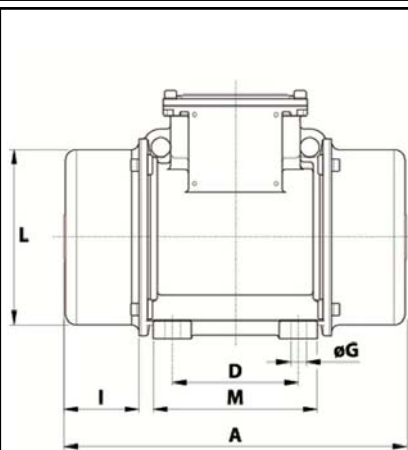

A	438
B	245
C	230
D	140
E	190
F	25
G	17
N° HOLES	4
H	116
I	103
L	201
M	180
N	225