

ACBMV B. CASADIO VIBRATION
 Z.I. Mi-Plaine
 51 Rue Ampère
 B.P. 31
 69682 CHASSIEU CEDEX (FRANCE)
 Tel.: 04 78 90 87 87 / Fax.: 04 78 90 87 88
 Email: vibrateur@orange.fr
 Internet: acbmv.com

2 POLES - 3600 RPM
 REF.: 600335C
 SIZE: 50

Certifications:



MECHANICAL AND ELECTRICAL SPECIFICATIONS

Eccentric weight setup (%)	Static moment (kgmm)	Working moment (kgcm)	Centrifugal force (kg)	Centrifugal force (kN)	Estimated bearings life time (hours)
100	128	25,60	1853	18,20	13939
90	115,20	23,04	1668	16,38	19792
80	102,40	20,48	1482	14,56	29353
70	89,60	17,92	1297	12,74	45781
60	76,80	15,36	1112	10,92	76466
50	64,00	12,80	927	9,10	>100000
40	51,20	10,24	741	7,28	>100000
30	38,40	7,68	556	5,46	>100000
20	25,60	5,12	371	3,64	>100000
10	12,80	2,56	185	1,82	>100000

Power supply (volts)	460
Phases:	three phases
Frequency (Hz)	60 Hz
Rotation speed (RPM)	3600
Max input power (watt)	2200
Max current (amp)	3
IS/IR	6

DIMENSIONAL SPECIFICATIONS (mm)

Vibrator weight: 46,3 kg

Continual service ambient temperature: -20°C à +40°C - Tropicalization anti-mold - Mechanical protection: IP66 IK08 according to IEC

Bearing type: ROLLER

Lubrication LONG-LIFE with KLUEBER ISOFLEX NBU 15.

Re lubrication quantity after 1000 hours of using: 16g

Max quantity by replaced bearing: 30g

Fixing with 4 screws M16 - 5/8" quality 8.8 with tightening torque (kgm - ft/lb): 19 - 137

Power supply cable size: 9 à 16 mm - Cable entry thread: M25x1,5

Maintenance space: 103 mm

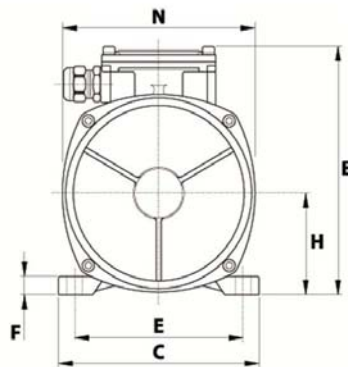
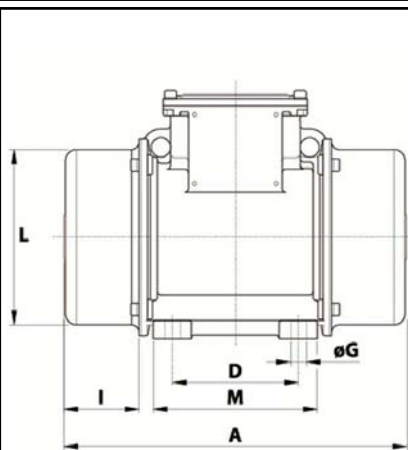

A	438
B	245
C	230
D	140
E	190
F	25
G	17
N° HOLES	4
H	116
I	103
L	201
M	180
N	225
