

ACBMV B. CASADIO VIBRATION
 Z.I. Mi-Plaine
 51 Rue Ampère
 B.P. 31
 69682 CHASSIEU CEDEX (FRANCE)
 Tel.: 04 78 90 87 87 / Fax.: 04 78 90 87 88
 Email: vibrateur@orange.fr
 Internet: acbmv.com

2 POLES - 3000 RPM ATEX II 2D tD A21 IP 66 ZONE 21-22
 REF.: 600375M Dust T°=120°C
 SIZE: 00

Certifications:



MECHANICAL AND ELECTRICAL SPECIFICATIONS

Eccentric weight setup (%)	Centrifugal force weight up/down (kg)	Static moment weight	Centrifugal force weight up/down (kN)	Static moment weight up (kgmm)	Estimated bearings life time (hours)
100	31/31	3	0,30/0,30	3	>100000
90	27,9/27,9	2,70	0,27/0,27	2,70	>100000
80	24,8/24,8	2,40	0,24/0,24	2,40	>100000
70	21,7/21,7	2,10	0,21/0,21	2,10	>100000
60	18,6/18,6	1,80	0,18/0,18	1,80	>100000
50	15,5/15,5	1,50	0,15/0,15	1,50	>100000
40	12,4/12,4	1,20	0,12/0,12	1,20	>100000
30	9,3/9,3	0,90	0,09/0,09	0,90	>100000
20	6,2/6,2	0,60	0,06/0,06	0,60	>100000
10	3,1/3,1	0,30	0,03/0,03	0,30	>100000

Power supply (volts)	400
Phases:	single phase
Frequency (Hz)	50 Hz
Rotation speed (RPM)	3000
Max input power (watt)	110
Max current (amp)	0,56
IS/IR	2,24

DIMENSIONAL SPECIFICATIONS (mm)

Vibrator weight: 5,4 kg

Continual service ambient temperature: -20°C à +40°C - Tropicalization anti-mold - Mechanical protection: IP66 IK08 according to IEC

Bearing type: BALL

Lubrication "FOR LIFE" with double protection screen

Fixing with 4 screws M8 - 5/16" quality 8.8 with tightening torque (kgm - ft/lb): 2.30 - 16.50

Power supply cable size: 6.5 à 12 mm - Cable entry thread: M20x1,5

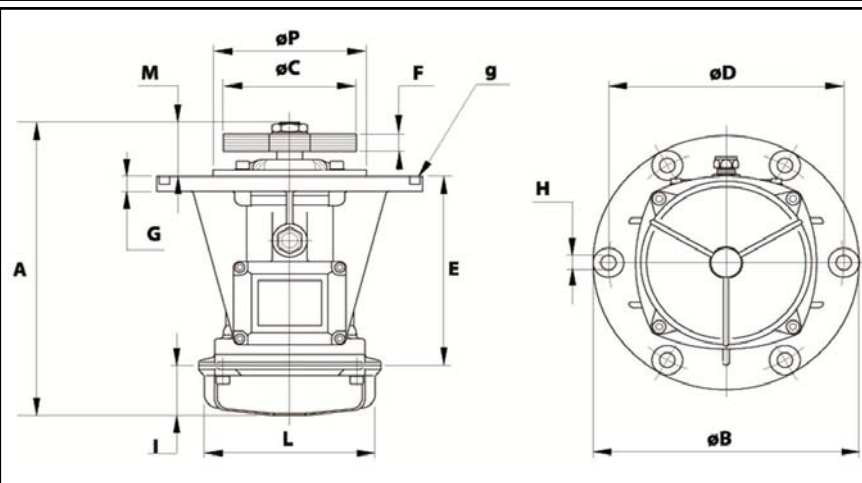

A	189
B	130
C	86
D	109
H	8,5
N° TROUS	4
E	132
F	7,5
G	10
I	36
L	96
M	22
P	-