

ACBMV B. CASADIO VIBRATION
 Z.I. Mi-Plaine
 51 Rue Ampère
 B.P. 31
 69682 CHASSIEU CEDEX (FRANCE)
 Tel.: 04 78 90 87 87 / Fax.: 04 78 90 87 88
 Email: vibrateur@orange.fr
 Internet: acbmv.com

2 POLES - 3600 RPM ATEX II 2D tD A21 IP 66 ZONE 21-22
 REF.: 600380C Dust T°=120°C
 SIZE: 30

Certifications:



MECHANICAL AND ELECTRICAL SPECIFICATIONS

Eccentric weight setup (%)	Centrifugal force weight up/down (kg)	Static moment weight	Centrifugal force weight up/down (kN)	Static moment weight up (kgmm)	Estimated bearings life time (hours)
100	377/377	26	3,70/3,70	26	12859
90	339,3/339,3	23,40	3,33/3,33	23,40	18270
80	301,6/301,6	20,80	2,96/2,96	20,80	27055
70	263,9/263,9	18,20	2,59/2,59	18,20	42223
60	226,2/226,2	15,60	2,22/2,22	15,60	70583
50	188,5/188,5	13,00	1,85/1,85	13,00	>100000
40	150,8/150,8	10,40	1,48/1,48	10,40	>100000
30	113,1/113,1	7,80	1,11/1,11	7,80	>100000
20	75,4/75,4	5,20	0,74/0,74	5,20	>100000
10	37,7/37,7	2,60	0,37/0,37	2,60	>100000

Power supply (volts)	460
Phases:	three phases
Frequency (Hz)	60 Hz
Rotation speed (RPM)	3600
Max input power (watt)	685
Max current (amp)	1
IS/IR	6

DIMENSIONAL SPECIFICATIONS (mm)

Vibrator weight: 16,5 kg

Continual service ambient temperature: -20°C à +40°C - Tropicalization anti-mold - Mechanical protection: IP66 IK08 according to IEC

Bearing type: ROLLER

Lubrication LONG-LIFE with KLUEBER ISOFLEX NBU 15.

Re lubrication quantity after 1000 hours of using: 8g

Max quantity by replaced bearing: 4g

Fixing with 6 screws M12 - 1/2" quality 8.8 with tightening torque (kgm - ft/lb): 13 - 94

Power supply cable size: 9 à 16 mm - Cable entry thread: M25x1,5

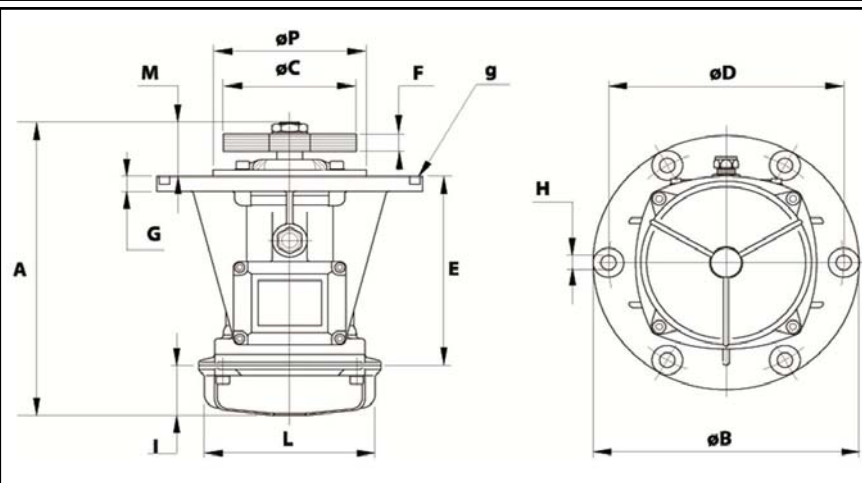

A	301
B	260
C	150 (50Hz) 132 (60Hz)
D	230
H	15
N° TROUS	6
E	182
F	18
G	15
I	63
L	170
M	56
P	150