

ACBMV B. CASADIO VIBRATION
 Z.I. Mi-Plaine
 51 Rue Ampère
 B.P. 31
 69682 CHASSIEU CEDEX (FRANCE)
 Tel.: 04 78 90 87 87 / Fax.: 04 78 90 87 88
 Email: vibrateur@orange.fr
 Internet: acbmv.com

2 POLES - 3000 RPM ATEX II 2D tD A21 IP 66 ZONE 21-22
 REF.: 600456M Dust T°=120°C
 SIZE: 20

Certifications:



MECHANICAL AND ELECTRICAL SPECIFICATIONS

Eccentric weight setup (%)	Centrifugal force weight up/down (kg)	Static moment weight	Centrifugal force weight up/down (kN)	Static moment weight up (kgmm)	Estimated bearings life time (hours)
100	393/251	22,4	3,86/2,46	39,1	2258
90	353,7/225,9	20,16	3,47/2,21	35,19	3098
80	314,4/200,8	17,92	3,09/1,97	31,28	4411
70	275,1/175,7	15,68	2,70/1,72	27,37	6584
60	235,8/150,6	13,44	2,32/1,48	23,46	10456
50	196,5/125,5	11,20	1,93/1,23	19,55	18067
40	157,2/100,4	8,96	1,54/0,98	15,64	35287
30	117,9/75,3	6,72	1,16/0,74	11,73	83644
20	78,6/50,2	4,48	0,77/0,49	7,82	>100000
10	39,3/25,1	2,24	0,39/0,25	3,91	>100000

Power supply (volts)	400
Phases:	single phase
Frequency (Hz)	50 Hz
Rotation speed (RPM)	3000
Max input power (watt)	500
Max current (amp)	2,3
IS/IR	3,35

DIMENSIONAL SPECIFICATIONS (mm)

Vibrator weight: 15,2 kg

Continual service ambient temperature: -20°C à +40°C - Tropicalization anti-mold - Mechanical protection: IP66 IK08 according to IEC

Bearing type: BALL

Lubrication "FOR LIFE" with double protection screen

Fixing with 6 screws M10 - 7/16" quality 8.8 with tightening torque (kgm - ft/lb): 4.80 - 35

Power supply cable size: 9 à 16 mm - Cable entry thread: M25x1,5

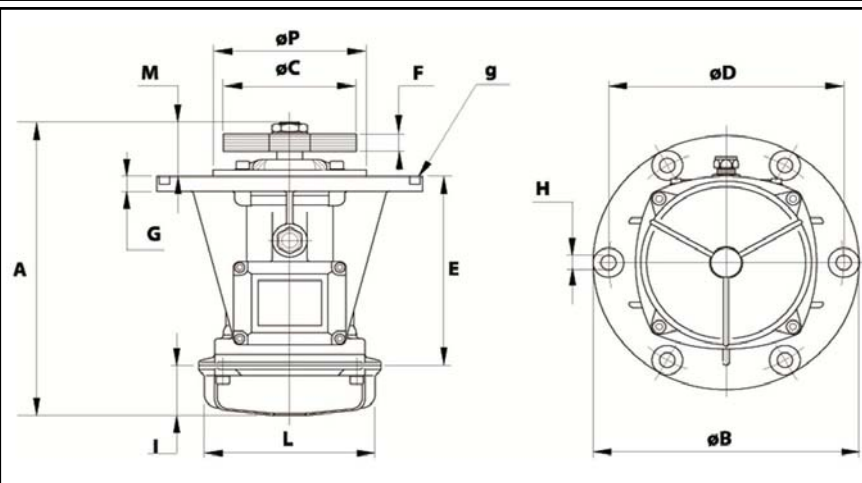

A	279,5
B	245
C	150 (50Hz) 132 (60Hz)
D	205
H	12
N° TROUS	6
E	124
F	18
G	12
I	65
L	145
M	90,5
P	162