

ACBMV B. CASADIO VIBRATION
 Z.I. Mi-Plaine
 51 Rue Ampère
 B.P. 31
 69682 CHASSIEU CEDEX (FRANCE)
 Tel.: 04 78 90 87 87 / Fax.: 04 78 90 87 88
 Email: vibrateur@orange.fr
 Internet: acbmv.com

0-6000 RPM
 REF.: 600509A
 SIZE: AF33

Certifications:



MECHANICAL AND ELECTRICAL SPECIFICATIONS

Eccentric weight setup (%)	Centrifugal force (kg)	Centrifugal force (kN)	Estimated bearings life time (hours)
100	2000	19,6	2000
90	1800	17,64	2743
80	1600	15,68	3906
70	1400	13,72	5831
60	1200	11,76	9259
50	1000	9,80	16000
40	800	7,84	31250
30	600	5,88	74074
20	400	3,92	>100000
10	200	1,96	>100000

Power supply (volts)	400
Phases:	three phases
Frequency (Hz)	100 Hz
Rotation speed (RPM)	6000
Max input power (watt)	1700
Max current (amp)	2,9
IS/IR	5

DIMENSIONAL SPECIFICATIONS (mm)

Vibrator weight: 24 kg

Continual service ambient temperature: -20°C à +40°C - Tropicalization anti-mold - Mechanical protection: IP66 IK08 according to IEC

Bearing type: BALL

Lubrication "FOR LIFE" with double protection screen

Fixing with cradle type: RS2

Power supply cable size: 9 à 16 mm - Cable entry thread: M25x1.5

Maintenance space: 106 mm

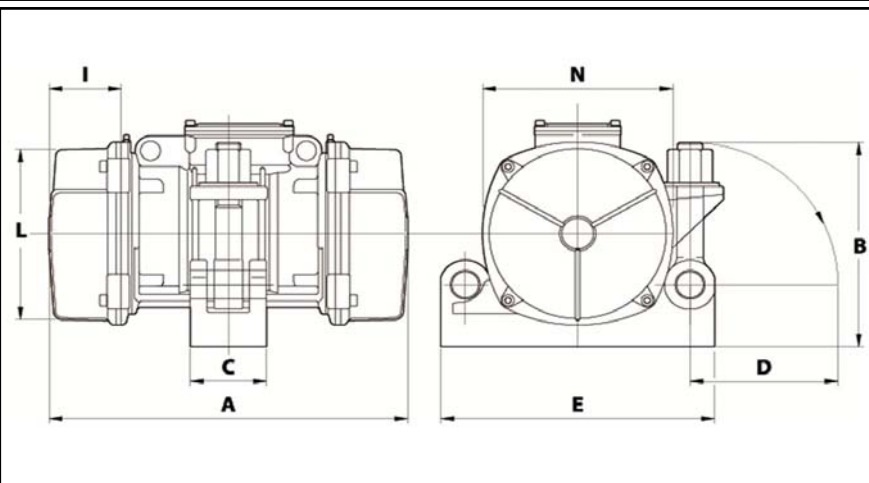

A	375
B	189
C	83
D	140
E	240
F	-
G	-
N° HOLES	-
H	-
I	106
L	170
M	-
N	182
