

ACBMV B. CASADIO VIBRATION
 Z.I. Mi-Plaine
 51 Rue Ampère
 B.P. 31
 69682 CHASSIEU CEDEX (FRANCE)
 Tel.: 04 78 90 87 87 / Fax.: 04 78 90 87 88
 Email: vibrateur@orange.fr
 Internet: acbmv.com

4 POLES - 1500 RPM
 REF.: 601130A
 SIZE: 80

Certifications:



MECHANICAL AND ELECTRICAL SPECIFICATIONS

Eccentric weight setup (%)	Centrifugal force (kg)	Centrifugal force (kN)	Estimated bearings life time (hours)
100	4500	44,1	20662
90	4050	39,69	29356
80	3600	35,28	43472
70	3150	30,87	67844
60	2700	26,46	>100000
50	2250	22,05	>100000
40	1800	17,64	>100000
30	1350	13,23	>100000
20	900	8,82	>100000
10	450	4,41	>100000

Power supply (volts)	400
Phases:	three phases
Frequency (Hz)	50 Hz
Rotation speed (RPM)	1500
Max input power (watt)	4000
Max current (amp)	6,7
IS/IR	4,48

DIMENSIONAL SPECIFICATIONS (mm)

Vibrator weight: 106 kg

Continual service ambient temperature: -20°C à +40°C - Tropicalization anti-mold - Mechanical protection: IP66 IK08 according to IEC

Bearing type: ROLLER

Lubrication LONG-LIFE with KLUEBER STABURAGS NBU 8EP.

Re lubrication quantity after 1000 hours of using: 100g

Max quantity by replaced bearing: 50g

Fixing with 6 screws M22 - 7/8" quality 8.8 with tightening torque (kgm - ft/lb): 56 - 411

Power supply cable size: 12.5 à 15 mm - Cable entry thread: M25x1,5

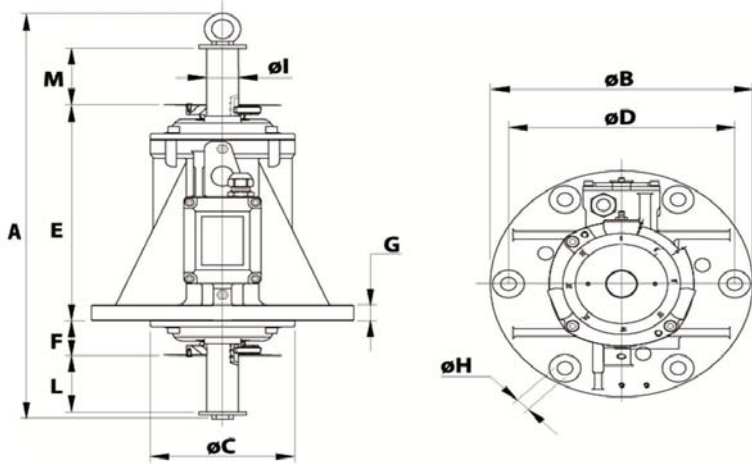

A	664
B	400
C	240
D	355
E	340
F	70
G	30
N° HOLES	6
H	23,5
I	52
L	75
M	75