

ACBMV B. CASADIO VIBRATION  
 Z.I. Mi-Plaine  
 51 Rue Ampère  
 B.P. 31  
 69682 CHASSIEU CEDEX (FRANCE)  
 Tel.: 04 78 90 87 87 / Fax.: 04 78 90 87 88  
 Email: [vibrateur@orange.fr](mailto:vibrateur@orange.fr)  
 Internet: [acbmv.com](http://acbmv.com)

4 POLES - 1800 RPM  
 REF.: 601136C  
 SIZE: 90

Certifications:



### MECHANICAL AND ELECTRICAL SPECIFICATIONS

Eccentric weight setup (%)	Centrifugal force (kg)	Centrifugal force (kN)	Estimated bearings life time (hours)
100	7000	68,7	12635
90	6300	61,83	17951
80	5600	54,96	26583
70	4900	48,09	41487
60	4200	41,22	69354
50	3500	34,35	>100000
40	2800	27,48	>100000
30	2100	20,61	>100000
20	1400	13,74	>100000
10	700	6,87	>100000

Power supply (volts)	460
Phases:	three phases
Frequency (Hz)	60 Hz
Rotation speed (RPM)	1800
Max input power (watt)	7000
Max current (amp)	10,2
IS/IR	6,73

### DIMENSIONAL SPECIFICATIONS (mm)

**Vibrator weight: 160 kg**

Continual service ambient temperature: -20°C à +40°C - Tropicalization anti-mold - Mechanical protection: IP66 IK08 according to IEC

Bearing type: ROLLER

Lubrication LONG-LIFE with KLUEBER STABURAGS NBU 8EP.

Re lubrication quantity after 1000 hours of using: 150g

Max quantity by replaced bearing: 80g

Fixing with 8 screws M24 - 15/16" quality 8.8 with tightening torque (kgm - ft/lb): 71 - 513

Power supply cable size: 16 à 19 mm - Cable entry thread: M32x1,5

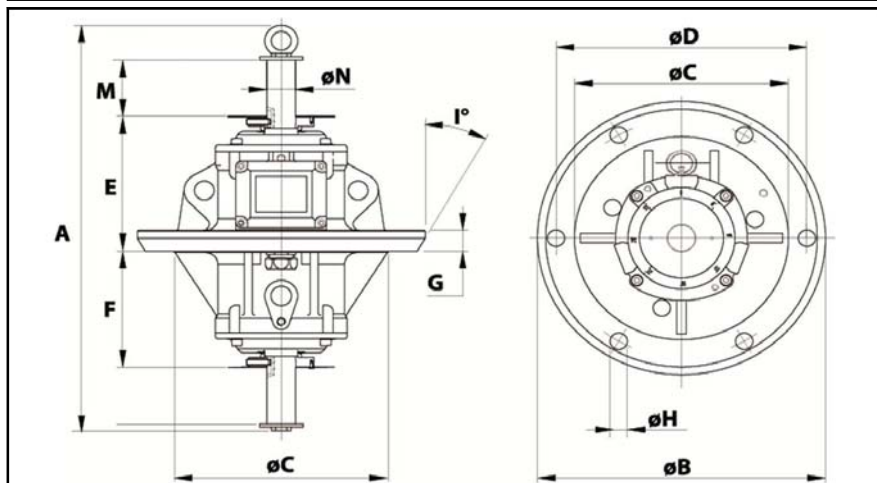

A	740
B	508
C	348
D	438
E	255,5
F	224,5
G	32,5
N° HOLES	8
H	25
I	30
L	79
M	79
N	52