

ACBMV B. CASADIO VIBRATION  
 Z.I. Mi-Plaine  
 51 Rue Ampère  
 B.P. 31  
 69682 CHASSIEU CEDEX (FRANCE)  
 Tel.: 04 78 90 87 87 / Fax.: 04 78 90 87 88  
 Email: [vibrateur@orange.fr](mailto:vibrateur@orange.fr)  
 Internet: [acbmv.com](http://acbmv.com)

4 POLES - 1500 RPM      ATEX II 2D tD A21 IP 66 ZONE 21-22  
 REF.: 601165A              Dust T°=135°C  
 SIZE: 90

Certifications:



### MECHANICAL AND ELECTRICAL SPECIFICATIONS

Eccentric weight setup (%)	Static moment (kgmm)	Working moment (kgcm)	Centrifugal force (kg)	Centrifugal force (kN)	Estimated bearings life time (hours)
100	2598,00	519,60	6536	64,10	17631
90	2338,20	467,64	5882	57,69	25055
80	2078,40	415,68	5229	51,28	37090
70	1818,60	363,72	4575	44,87	57900
60	1558,80	311,76	3922	38,46	96744
50	1299,00	259,80	3268	32,05	>100000
40	1039,20	207,84	2614	25,64	>100000
30	779,40	155,88	1961	19,23	>100000
20	519,60	103,92	1307	12,82	>100000
10	259,80	51,96	654	6,41	>100000

Power supply (volts)	400
Phases:	three phases
Frequency (Hz)	50 Hz
Rotation speed (RPM)	1500
Max input power (watt)	6000
Max current (amp)	10,50
IS/IR	6,48

### DIMENSIONAL SPECIFICATIONS (mm)

**Vibrator weight: 208,0 kg**

Continual service ambient temperature: -20°C à +40°C - Tropicalization anti-mold - Mechanical protection: IP66 IK08 according to IEC

Bearing type: ROLLER

Lubrication LONG-LIFE with KLUEBER STABURAGS NBU 8EP.

Re lubrication quantity after 1000 hours of using: 60g

Max quantity by replaced bearing: 120g

Fixing with 4 screws M27 - 1" quality 8.8 with tightening torque (kgm - ft/lb): 89 - 645

Power supply cable size: 13 à 20 mm - Cable entry thread: M32x1,5

Maintenance space: 160 mm

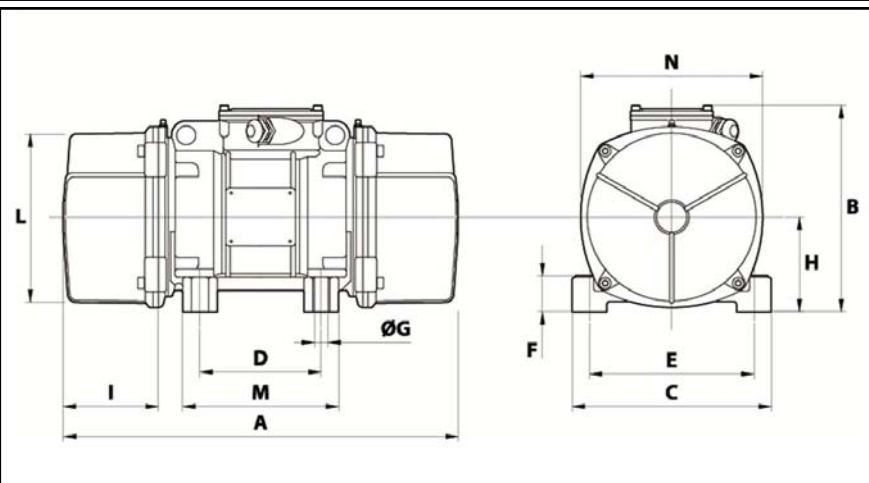

A	680
B	370
C	390
D	200
E	320
F	90
G	28
N° HOLES	4
H	180
I	160
L	330
M	270
N	350