

ACBMV B. CASADIO VIBRATION
 Z.I. Mi-Plaine
 51 Rue Ampère
 B.P. 31
 69682 CHASSIEU CEDEX (FRANCE)
 Tel.: 04 78 90 87 87 / Fax.: 04 78 90 87 88
 Email: vibrateur@orange.fr
 Internet: acbmv.com

4 POLES - 1500 RPM ATEX II 2D tD A21 IP 66 ZONE 21-22
 REF.: 601205A Dust T°=135°C
 SIZE: 100

Certifications:



MECHANICAL AND ELECTRICAL SPECIFICATIONS

Eccentric weight setup (%)	Static moment (kgmm)	Working moment (kgcm)	Centrifugal force (kg)	Centrifugal force (kN)	Estimated bearings life time (hours)
100	4544,00	908,80	11430	112,00	18119
90	4089,60	817,92	10287	100,80	25743
80	3635,20	727,04	9144	89,60	38121
70	3180,80	636,16	8001	78,40	59494
60	2726,40	545,28	6858	67,20	99456
50	2272,00	454,40	5715	56,00	>100000
40	1817,60	363,52	4572	44,80	>100000
30	1363,20	272,64	3429	33,60	>100000
20	908,80	181,76	2286	22,40	>100000
10	454,40	90,88	1143	11,20	>100000

Power supply (volts)	400
Phases:	three phases
Frequency (Hz)	50 Hz
Rotation speed (RPM)	1500
Max input power (watt)	10000
Max current (amp)	17,50
IS/IR	7,03

DIMENSIONAL SPECIFICATIONS (mm)

Vibrator weight: 433,0 kg

Continual service ambient temperature: -20°C à +40°C - Tropicalization anti-mold - Mechanical protection: IP66 IK08 according to IEC

Bearing type: ROLLER

Lubrication LONG-LIFE with KLUEBER STABURAGS NBU 8EP.

Re lubrication quantity after 1000 hours of using: 130g

Max quantity by replaced bearing: 260g

Fixing with 6 screws M42 - 1 5/8" quality 8.8 with tightening torque (kgm - ft/lb): 290 - 2090

Power supply cable size: 13 à 20 mm - Cable entry thread: M32x1,5

Maintenance space: 240 mm

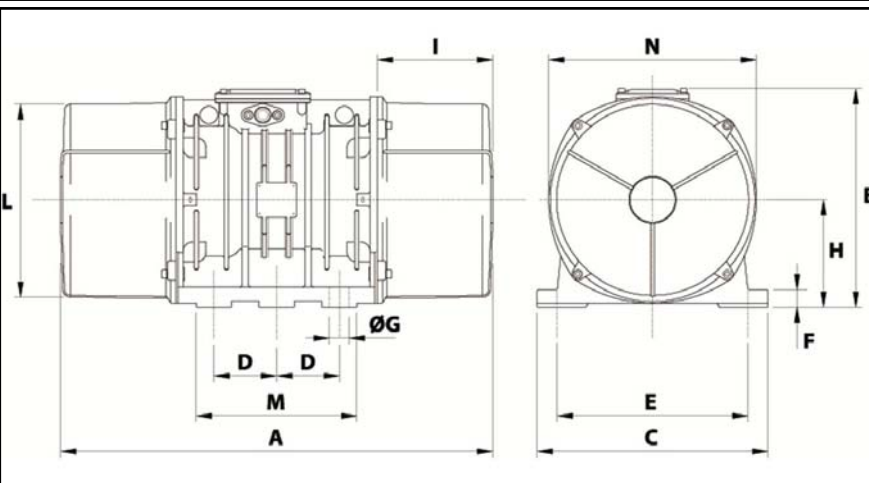

A	990
B	454
C	530
D	140
E	440
F	38
G	45
N° HOLES	6
H	230
I	240
L	423
M	370
N	448