

ACBMV B. CASADIO VIBRATION
 Z.I. Mi-Plaine
 51 Rue Ampère
 B.P. 31
 69682 CHASSIEU CEDEX (FRANCE)
 Tel.: 04 78 90 87 87 / Fax.: 04 78 90 87 88
 Email: vibrateur@orange.fr
 Internet: acbmv.com

4 POLES - 1800 RPM ATEX II 2D tD A21 IP 66 ZONE 21-22
 REF.: 601211C Dust T°=135°C
 SIZE: 80

Certifications:



MECHANICAL AND ELECTRICAL SPECIFICATIONS

Eccentric weight setup (%)	Static moment (kgmm)	Working moment (kgcm)	Centrifugal force (kg)	Centrifugal force (kN)	Estimated bearings life time (hours)
100	1364,00	272,80	4941	48,50	14310
90	1227,60	245,52	4447	43,65	20330
80	1091,20	218,24	3953	38,80	30102
70	954,80	190,96	3459	33,95	46974
60	818,40	163,68	2965	29,10	78513
50	682,00	136,40	2471	24,25	>100000
40	545,60	109,12	1976	19,40	>100000
30	409,20	81,84	1482	14,55	>100000
20	272,80	54,56	988	9,70	>100000
10	136,40	27,28	494	4,85	>100000

Power supply (volts)	460
Phases:	three phases
Frequency (Hz)	60 Hz
Rotation speed (RPM)	1800
Max input power (watt)	3400
Max current (amp)	5,00
IS/IR	8,00

DIMENSIONAL SPECIFICATIONS (mm)

Vibrator weight: 153,0 kg

Continual service ambient temperature: -20°C à +40°C - Tropicalization anti-mold - Mechanical protection: IP66 IK08 according to IEC
 Bearing type: ROLLER
 Lubrication LONG-LIFE with KLUEBER STABURAGS NBU 8EP.
 Re lubrication quantity after 1000 hours of using: 40g
 Max quantity by replaced bearing: 80g
 Fixing with 4 screws M24 - 15/16" quality 8.8 with tightening torque (kgm - ft/lb): 71 - 513
 Power supply cable size: 13 à 20 mm - Cable entry thread: M32x1,5
 Maintenance space: 150 mm

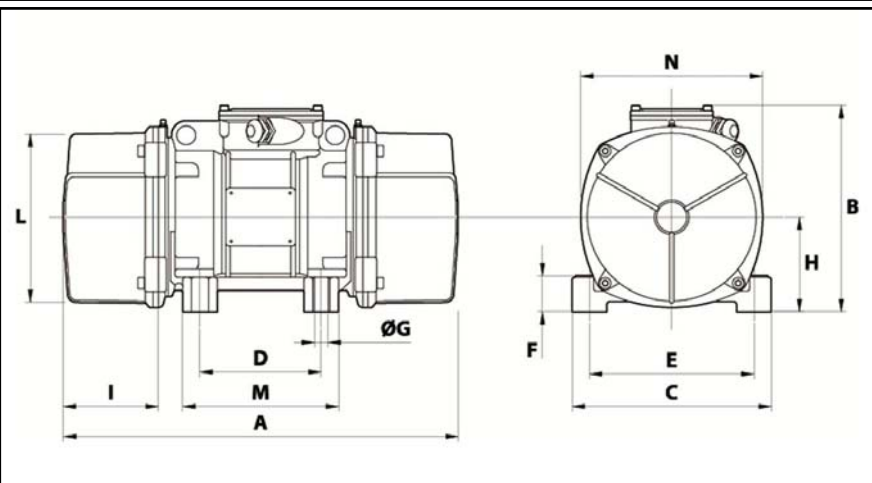

A	630
B	347
C	340
D	180
E	280
F	80
G	26
N° HOLES	4
H	165
I	150
L	303
M	240
N	320