

ACBMV B. CASADIO VIBRATION  
 Z.I. Mi-Plaine  
 51 Rue Ampère  
 B.P. 31  
 69682 CHASSIEU CEDEX (FRANCE)  
 Tel.: 04 78 90 87 87 / Fax.: 04 78 90 87 88  
 Email: [vibrateur@orange.fr](mailto:vibrateur@orange.fr)  
 Internet: [acbmv.com](http://acbmv.com)

4 POLES - 1500 RPM      ATEX II 2D tD A21 IP 66 ZONE 21-22  
 REF.: 601221A              Dust T°=135°C  
 SIZE: 70

Certifications:



### MECHANICAL AND ELECTRICAL SPECIFICATIONS

Eccentric weight setup (%)	Static moment (kgmm)	Working moment (kgcm)	Centrifugal force (kg)	Centrifugal force (kN)	Estimated bearings life time (hours)
100	1526,00	305,20	3840	37,70	20040
90	1373,40	274,68	3456	33,93	28472
80	1220,80	244,16	3072	30,16	42163
70	1068,20	213,64	2688	26,39	65802
60	915,60	183,12	2304	22,62	>100000
50	763,00	152,60	1920	18,85	>100000
40	610,40	122,08	1536	15,08	>100000
30	457,80	91,56	1152	11,31	>100000
20	305,20	61,04	768	7,54	>100000
10	152,60	30,52	384	3,77	>100000

Power supply (volts)	400
Phases:	three phases
Frequency (Hz)	50 Hz
Rotation speed (RPM)	1500
Max input power (watt)	2200
Max current (amp)	3,90
IS/IR	7,11

### DIMENSIONAL SPECIFICATIONS (mm)

**Vibrator weight: 119,0 kg**

Continual service ambient temperature: -20°C à +40°C - Tropicalization anti-mold - Mechanical protection: IP66 IK08 according to IEC

Bearing type: ROLLER

Lubrication LONG-LIFE with KLUEBER STABURAGS NBU 8EP.

Re lubrication quantity after 1000 hours of using: 26g

Max quantity by replaced bearing: 40g

Fixing with 4 screws M22 - 7/8" quality 8.8 with tightening torque (kgm - ft/lb): 56 - 411

Power supply cable size: 9 à 16 mm - Cable entry thread: M25x1,5

Maintenance space: 137 mm

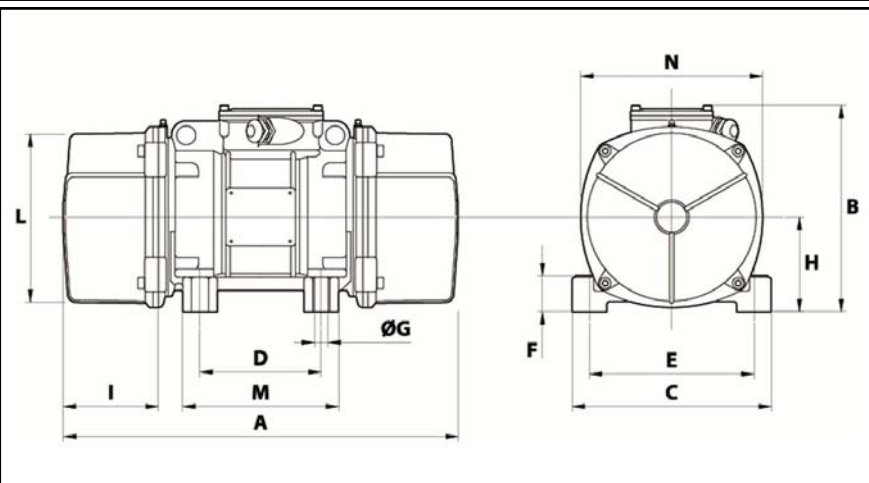

A	584
B	321
C	310
D	155
E	255
F	77
G	24
N° HOLES	4
H	157
I	137
L	277
M	215
N	295
