

ACBMV B. CASADIO VIBRATION
 Z.I. Mi-Plaine
 51 Rue Ampère
 B.P. 31
 69682 CHASSIEU CEDEX (FRANCE)
 Tel.: 04 78 90 87 87 / Fax.: 04 78 90 87 88
 Email: vibrateur@orange.fr
 Internet: acbmv.com

4 POLES - 1800 RPM ATEX II 2D tD A21 IP 66 ZONE 21-22
 REF.: 601271C Dust T°=135°C
 SIZE: 100

Certifications:



MECHANICAL AND ELECTRICAL SPECIFICATIONS

Eccentric weight setup (%)	Static moment (kgmm)	Working moment (kgcm)	Centrifugal force (kg)	Centrifugal force (kN)	Estimated bearings life time (hours)
100	4126,00	825,20	14940	147,00	6184
90	3713,40	742,68	13446	132,30	8786
80	3300,80	660,16	11952	117,60	13011
70	2888,20	577,64	10458	102,90	20305
60	2475,60	495,12	8964	88,20	33944
50	2063,00	412,60	7470	73,50	62331
40	1650,40	330,08	5976	58,80	>100000
30	1237,80	247,56	4482	44,10	>100000
20	825,20	165,04	2988	29,40	>100000
10	412,60	82,52	1494	14,70	>100000

Power supply (volts)	460
Phases:	three phases
Frequency (Hz)	60 Hz
Rotation speed (RPM)	1800
Max input power (watt)	12000
Max current (amp)	20,00
IS/IR	8,00

DIMENSIONAL SPECIFICATIONS (mm)

Vibrator weight: 424,0 kg

Continual service ambient temperature: -20°C à +40°C - Tropicalization anti-mold - Mechanical protection: IP66 IK08 according to IEC

Bearing type: ROLLER

Lubrication LONG-LIFE with KLUEBER STABURAGS NBU 8EP.

Re lubrication quantity after 1000 hours of using: 150g

Max quantity by replaced bearing: 300g

Fixing with 6 screws M42 - 1 5/8" quality 8.8 with tightening torque (kgm - ft/lb): 290 - 2090

Power supply cable size: 13 à 20 mm - Cable entry thread: M32x1,5

Maintenance space: 240 mm

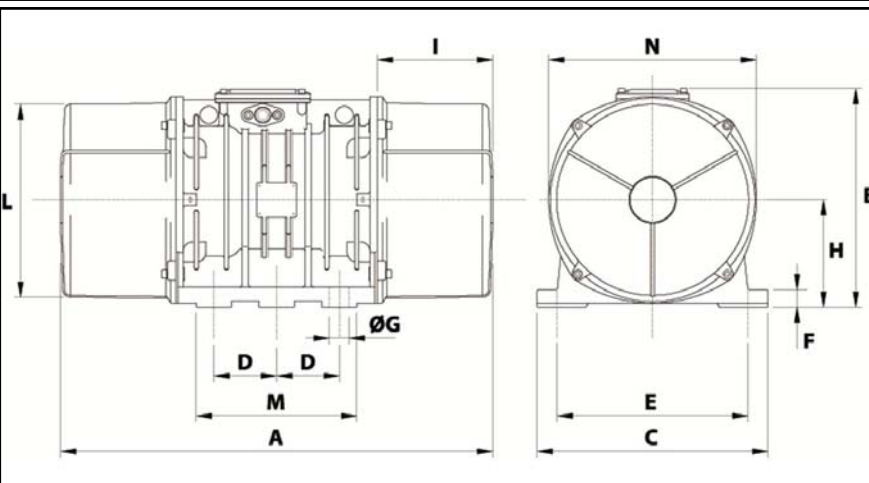

A	990
B	454
C	530
D	140
E	440
F	38
G	45
N° HOLES	6
H	230
I	240
L	423
M	370
N	448