

ACBMV B. CASADIO VIBRATION  
 Z.I. Mi-Plaine  
 51 Rue Ampère  
 B.P. 31  
 69682 CHASSIEU CEDEX (FRANCE)  
 Tel.: 04 78 90 87 87 / Fax.: 04 78 90 87 88  
 Email: [vibrateur@orange.fr](mailto:vibrateur@orange.fr)  
 Internet: [acbm.com](http://acbm.com)

4 POLES - 1800 RPM  
 REF.: 601330C  
 SIZE: 70

Certifications:

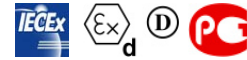

### MECHANICAL AND ELECTRICAL SPECIFICATIONS

Eccentric weight setup (%)	Static moment (kgmm)	Working moment (kgcm)	Centrifugal force (kg)	Centrifugal force (kN)	Estimated bearings life time (hours)
100	1034	206,80	3744	36,70	16175
90	930,60	186,12	3370	33,03	22972
80	827,20	165,44	2995	29,36	34039
70	723,80	144,76	2621	25,69	53097
60	620,40	124,08	2246	22,02	88838
50	517,00	103,40	1872	18,35	>100000
40	413,60	82,72	1498	14,68	>100000
30	310,20	62,04	1123	11,01	>100000
20	206,80	41,36	749	7,34	>100000
10	103,40	20,68	374	3,67	>100000

Power supply (volts)	460
Phases:	three phases
Frequency (Hz)	60 Hz
Rotation speed (RPM)	1800
Max input power (watt)	Input: 2250 Rating: 1845
Max current (amp)	3,5
IS/IR	8,09

### DIMENSIONAL SPECIFICATIONS (mm)

**Vibrator weight: 128 kg**

Continual service ambient temperature: -20°C à +40°C - Tropicalization anti-mold - Mechanical protection: IP66 IK08 according to IEC

Bearing type: ROLLER

Lubrication LONG-LIFE with KLUEBER STABURAGS NBU 8EP.

Re lubrication quantity after 1000 hours of using: 30g

Max quantity by replaced bearing: 60g

Fixing with 4 screws M22 - 7/8" quality 8.8 with tightening torque (kgm - ft/lb): 56 - 411

- Thread (pipe thread not supplied): NPT3/4"

Maintenance space: 137 mm

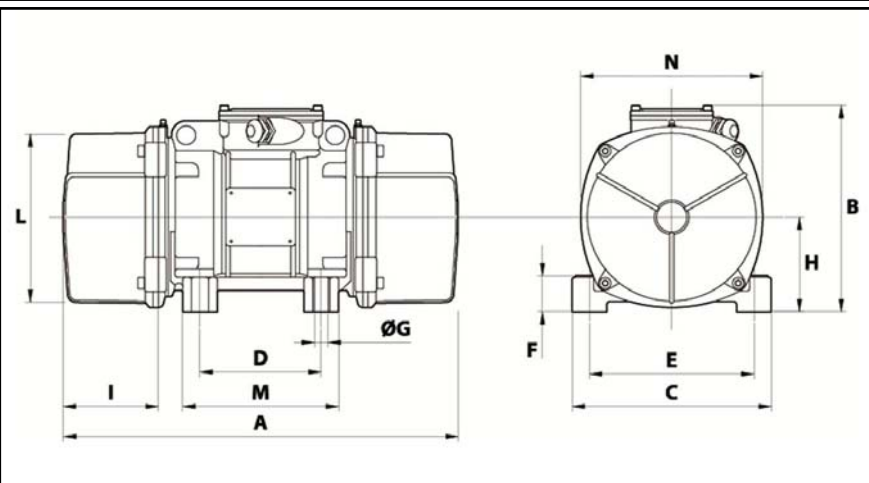

A	594
B	342,5
C	310
D	155
E	255
F	65
G	23,5
N° HOLES	4
H	155
I	137
L	279
M	210
N	295