

ACBMV B. CASADIO VIBRATION
 Z.I. Mi-Plaine
 51 Rue Ampère
 B.P. 31
 69682 CHASSIEU CEDEX (FRANCE)
 Tel.: 04 78 90 87 87 / Fax.: 04 78 90 87 88
 Email: vibrateur@orange.fr
 Internet: acbmv.com

4 POLES - 1800 RPM
 REF.: 601342C
 SIZE: 00

Certifications:



MECHANICAL AND ELECTRICAL SPECIFICATIONS

Eccentric weight setup (%)	Static moment (kgmm)	Working moment (kgcm)	Centrifugal force (kg)	Centrifugal force (kN)	Estimated bearings life time (hours)
100	12	2,40	43,5	0,43	>100000
90	10,80	2,16	39	0,39	>100000
80	9,60	1,92	35	0,34	>100000
70	8,40	1,68	30	0,30	>100000
60	7,20	1,44	26	0,26	>100000
50	6,00	1,20	22	0,22	>100000
40	4,80	0,96	17	0,17	>100000
30	3,60	0,72	13	0,13	>100000
20	2,40	0,48	9	0,09	>100000
10	1,20	0,24	4	0,04	>100000

Power supply (volts)	260
Phases:	single phase
Frequency (Hz)	60 Hz
Rotation speed (RPM)	1800
Max input power (watt)	100
Max current (amp)	1
IS/IR	1,3

DIMENSIONAL SPECIFICATIONS (mm)

Vibrator weight: 7,8 kg

Continual service ambient temperature: -20°C à +40°C - Tropicalization anti-mold - Mechanical protection: IP66 IK08 according to IEC

Bearing type: BALL

Lubrication "FOR LIFE" with double protection screen

Fixing with 4 screws M8 - 5/16" quality 8.8 with tightening torque (kgm - ft/lb): 2.30 - 16.50

Power supply cable size: 6.5 à 12 mm - Cable entry thread: M20x1,5

Maintenance space: 45 mm

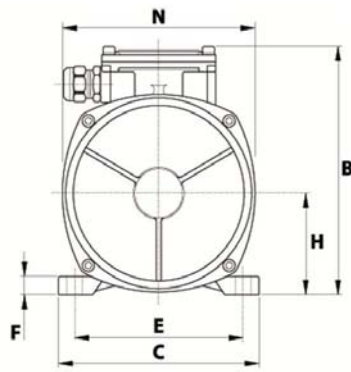
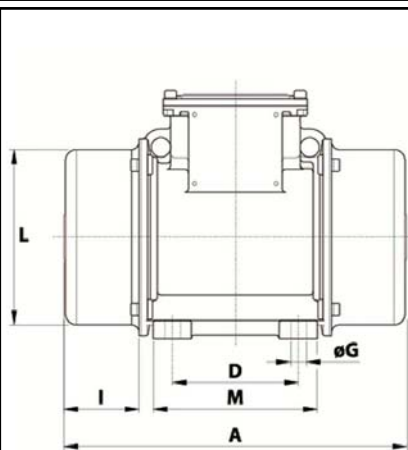

A	209
B	151
C	125
D	62-74**
E	106
F	10
G	9
N° HOLES	4
H	61
I	45
L	100
M	102
N	117

**					
Slot					