

ACBMV B. CASADIO VIBRATION  
 Z.I. Mi-Plaine  
 51 Rue Ampère  
 B.P. 31  
 69682 CHASSIEU CEDEX (FRANCE)  
 Tel.: 04 78 90 87 87 / Fax.: 04 78 90 87 88  
 Email: [vibrateur@orange.fr](mailto:vibrateur@orange.fr)  
 Internet: [acbmv.com](http://acbmv.com)

4 POLES - 1500 RPM  
 REF.: 601348A  
 SIZE: 35

Certifications:



### MECHANICAL AND ELECTRICAL SPECIFICATIONS

Eccentric weight setup (%)	Static moment (kgmm)	Working moment (kgcm)	Centrifugal force (kg)	Centrifugal force (kN)	Estimated bearings life time (hours)
100	415	83,00	1045	10,30	15542
90	373,50	74,70	941	9,27	22043
80	332,00	66,40	836	8,24	32699
70	290,50	58,10	732	7,21	50916
60	249,00	49,80	627	6,18	85311
50	207,50	41,50	523	5,15	>100000
40	166,00	33,20	418	4,12	>100000
30	124,50	24,90	314	3,09	>100000
20	83,00	16,60	209	2,06	>100000
10	41,50	8,30	105	1,03	>100000

Power supply (volts)	400
Phases:	three phases
Frequency (Hz)	50 Hz
Rotation speed (RPM)	1500
Max input power (watt)	550
Max current (amp)	0,95
IS/IR	4,89

### DIMENSIONAL SPECIFICATIONS (mm)

**Vibrator weight: 42 kg**

Continual service ambient temperature: -20°C à +40°C - Tropicalization anti-mold - Mechanical protection: IP66 IK08 according to IEC

Bearing type: ROLLER

Lubrication LONG-LIFE with KLUEBER STABURAGS NBU 8EP.

Re lubrication quantity after 1000 hours of using: 7g

Max quantity by replaced bearing: 12g

Fixing with 4 screws M16 - 5/8" quality 8.8 with tightening torque (kgm - ft/lb): 19 - 137

Power supply cable size: 9 à 16 mm - Cable entry thread: M25x1,5

Maintenance space: 117 mm

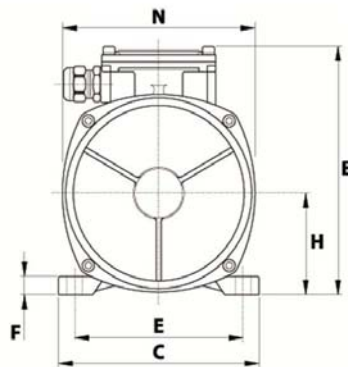
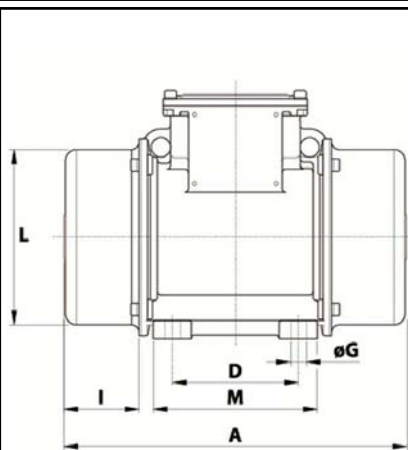

A	434
B	232
C	205
D	120
E	170
F	20
G	17
N° HOLES	4
H	104,5
I	117
L	181
M	162
N	203-
