

ACBMV B. CASADIO VIBRATION
 Z.I. Mi-Plaine
 51 Rue Ampère
 B.P. 31
 69682 CHASSIEU CEDEX (FRANCE)
 Tel.: 04 78 90 87 87 / Fax.: 04 78 90 87 88
 Email: vibrateur@orange.fr
 Internet: acbmv.com

4 POLES - 1800 RPM
 REF.: 601348C
 SIZE: 35

Certifications:



MECHANICAL AND ELECTRICAL SPECIFICATIONS

Eccentric weight setup (%)	Static moment (kgmm)	Working moment (kgcm)	Centrifugal force (kg)	Centrifugal force (kN)	Estimated bearings life time (hours)
100	271	54,20	982	9,63	15935
90	243,90	48,78	884	8,67	22623
80	216,80	43,36	786	7,70	33469
70	189,70	37,94	687	6,74	52425
60	162,60	32,52	589	5,78	87567
50	135,50	27,10	491	4,82	>100000
40	108,40	21,68	393	3,85	>100000
30	81,30	16,26	295	2,89	>100000
20	54,20	10,84	196	1,93	>100000
10	27,10	5,42	98	0,96	>100000

Power supply (volts)	460
Phases:	three phases
Frequency (Hz)	60 Hz
Rotation speed (RPM)	1800
Max input power (watt)	680
Max current (amp)	0,95
IS/IR	4,89

DIMENSIONAL SPECIFICATIONS (mm)

Vibrator weight: 37,5 kg

Continual service ambient temperature: -20°C à +40°C - Tropicalization anti-mold - Mechanical protection: IP66 IK08 according to IEC

Bearing type: ROLLER

Lubrication LONG-LIFE with KLUEBER STABURAGS NBU 8EP.

Re lubrication quantity after 1000 hours of using: 7g

Max quantity by replaced bearing: 12g

Fixing with 4 screws M16 - 5/8" quality 8.8 with tightening torque (kgm - ft/lb): 19 - 137

Power supply cable size: 9 à 16 mm - Cable entry thread: M25x1,5

Maintenance space: 117 mm

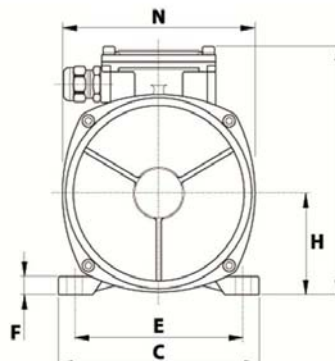
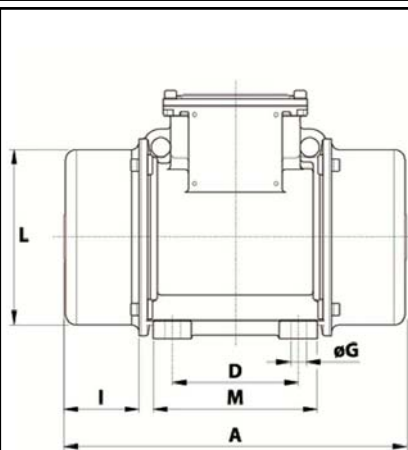

A	434
B	232
C	205
D	120
E	170
F	20
G	17
N° HOLES	4
H	104,5
I	117
L	181
M	162
N	203-