

ACBMV B. CASADIO VIBRATION
 Z.I. Mi-Plaine
 51 Rue Ampère
 B.P. 31
 69682 CHASSIEU CEDEX (FRANCE)
 Tel.: 04 78 90 87 87 / Fax.: 04 78 90 87 88
 Email: vibrateur@orange.fr
 Internet: acbmv.com

4 POLES - 1500 RPM
 REF.: 601352A
 SIZE: 60

Certifications:



MECHANICAL AND ELECTRICAL SPECIFICATIONS

Eccentric weight setup (%)	Static moment (kgmm)	Working moment (kgcm)	Centrifugal force (kg)	Centrifugal force (kN)	Estimated bearings life time (hours)
100	962	192,40	2420	23,70	27064
90	865,80	173,16	2178	21,33	38452
80	769,60	153,92	1936	18,96	56941
70	673,40	134,68	1694	16,59	88865
60	577,20	115,44	1452	14,22	>100000
50	481,00	96,20	1210	11,85	>100000
40	384,80	76,96	968	9,48	>100000
30	288,60	57,72	726	7,11	>100000
20	192,40	38,48	484	4,74	>100000
10	96,20	19,24	242	2,37	>100000

Power supply (volts)	400
Phases:	three phases
Frequency (Hz)	50 Hz
Rotation speed (RPM)	1500
Max input power (watt)	1600
Max current (amp)	3,2
IS/IR	7,23

DIMENSIONAL SPECIFICATIONS (mm)

Vibrator weight: 82 kg

Continual service ambient temperature: -20°C à +40°C - Tropicalization anti-mold - Mechanical protection: IP66 IK08 according to IEC

Bearing type: ROLLER

Lubrication LONG-LIFE with KLUEBER STABURAGS NBU 8EP.

Re lubrication quantity after 1000 hours of using: 19g

Max quantity by replaced bearing: 35g

Fixing with 4 screws M20 - 13/16" quality 8.8 with tightening torque (kgm - ft/lb): 38 - 275

Power supply cable size: 9 à 16 mm - Cable entry thread: M25x1,5

Maintenance space: 131 mm

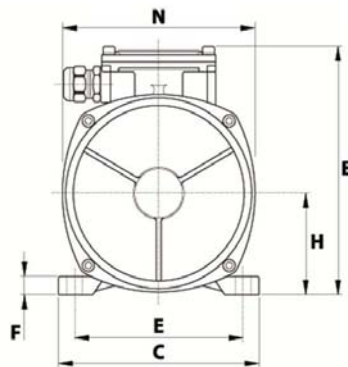
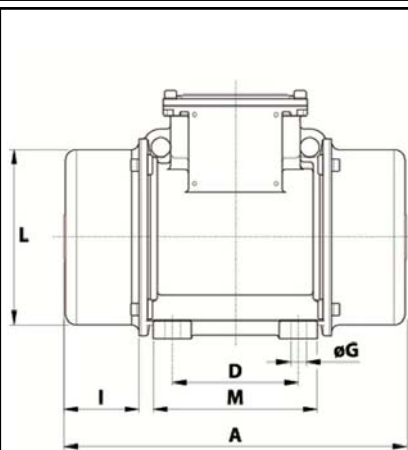

A	525
B	285
C	275
D	155
E	225
F	30
G	22
N° HOLES	4
H	135
I	131
L	231
M	205
N	253-
