

ACBMV B. CASADIO VIBRATION
 Z.I. Mi-Plaine
 51 Rue Ampère
 B.P. 31
 69682 CHASSIEU CEDEX (FRANCE)
 Tel.: 04 78 90 87 87 / Fax.: 04 78 90 87 88
 Email: vibrateur@orange.fr
 Internet: acbm.com

4 POLES - 1500 RPM ATEX II 2D tD A21 IP 66 ZONE 21-22
 REF.: 601366A Dust T°=120°C
 SIZE: 01

Certifications:



MECHANICAL AND ELECTRICAL SPECIFICATIONS

Eccentric weight setup (%)	Static moment (kgmm)	Working moment (kgcm)	Centrifugal force (kg)	Centrifugal force (kN)	Estimated bearings life time (hours)
100	38,90	7,78	98	0,96	74340
90	35,01	7,00	88	0,86	>100000
80	31,12	6,22	78	0,77	>100000
70	27,23	5,45	69	0,67	>100000
60	23,34	4,67	59	0,58	>100000
50	19,45	3,89	49	0,48	>100000
40	15,56	3,11	39	0,38	>100000
30	11,67	2,33	29	0,29	>100000
20	7,78	1,56	20	0,19	>100000
10	3,89	0,78	10	0,10	>100000

Power supply (volts)	400
Phases:	three phases
Frequency (Hz)	50 Hz
Rotation speed (RPM)	1500
Max input power (watt)	85
Max current (amp)	0,21
IS/IR	1,78

DIMENSIONAL SPECIFICATIONS (mm)

Vibrator weight: 7,1 kg

Continual service ambient temperature: -20°C à +40°C - Tropicalization anti-mold - Mechanical protection: IP66 IK08 according to IEC

Bearing type: BALL

Lubrication "FOR LIFE" with double protection screen

Fixing with 4 screws M8 - 5/16" quality 8.8 with tightening torque (kgm - ft/lb): 2.30 - 16.50

Power supply cable size: 6.5 à 12 mm - Cable entry thread: M20x1,5

Maintenance space: 65 (50Hz) 58 (60Hz) mm

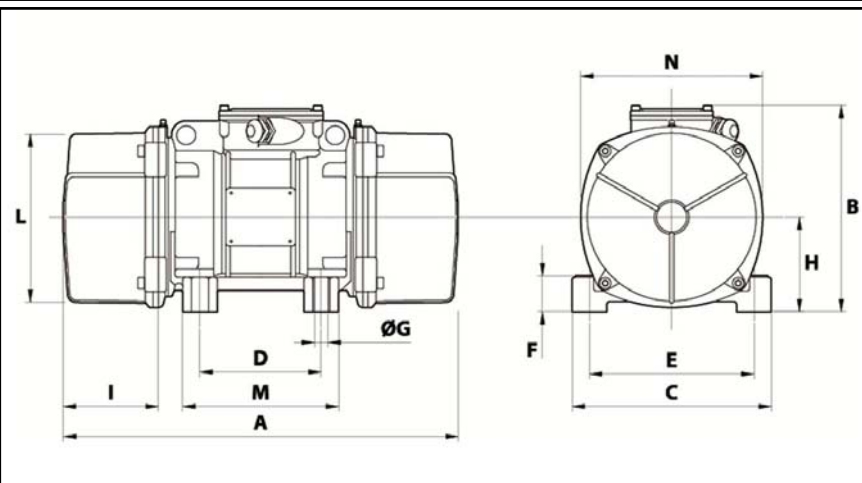

A	249
B	153
C	125
D	62-74**
E	106
F	24
G	9
N° HOLES	4
H	61
I	65
L	103
M	100
N	117

**					
Slot					