

ACBMV B. CASADIO VIBRATION
 Z.I. Mi-Plaine
 51 Rue Ampère
 B.P. 31
 69682 CHASSIEU CEDEX (FRANCE)
 Tel.: 04 78 90 87 87 / Fax.: 04 78 90 87 88
 Email: vibrateur@orange.fr
 Internet: acbm.com

4 POLES - 1800 RPM ATEX II 2D tD A21 IP 66 ZONE 21-22
 REF.: 601366C Dust T°=120°C
 SIZE: 01

Certifications:



MECHANICAL AND ELECTRICAL SPECIFICATIONS

Eccentric weight setup (%)	Static moment (kgmm)	Working moment (kgcm)	Centrifugal force (kg)	Centrifugal force (kN)	Estimated bearings life time (hours)
100	31,00	6,20	112	1,10	41787
90	27,90	5,58	101	0,99	56981
80	24,80	4,96	90	0,88	80532
70	21,70	4,34	78	0,77	>100000
60	18,60	3,72	67	0,66	>100000
50	15,50	3,10	56	0,55	>100000
40	12,40	2,48	45	0,44	>100000
30	9,30	1,86	34	0,33	>100000
20	6,20	1,24	22	0,22	>100000
10	3,10	0,62	11	0,11	>100000

Power supply (volts)	460
Phases:	three phases
Frequency (Hz)	60 Hz
Rotation speed (RPM)	1800
Max input power (watt)	95
Max current (amp)	0,20
IS/IR	1,95

DIMENSIONAL SPECIFICATIONS (mm)

Vibrator weight: 6,7 kg

Continual service ambient temperature: -20°C à +40°C - Tropicalization anti-mold - Mechanical protection: IP66 IK08 according to IEC

Bearing type: BALL

Lubrication "FOR LIFE" with double protection screen

Fixing with 4 screws M8 - 5/16" quality 8.8 with tightening torque (kgm - ft/lb): 2.30 - 16.50

Power supply cable size: 6.5 à 12 mm - Cable entry thread: M20x1,5

Maintenance space: 65 (50Hz) 58 (60Hz) mm

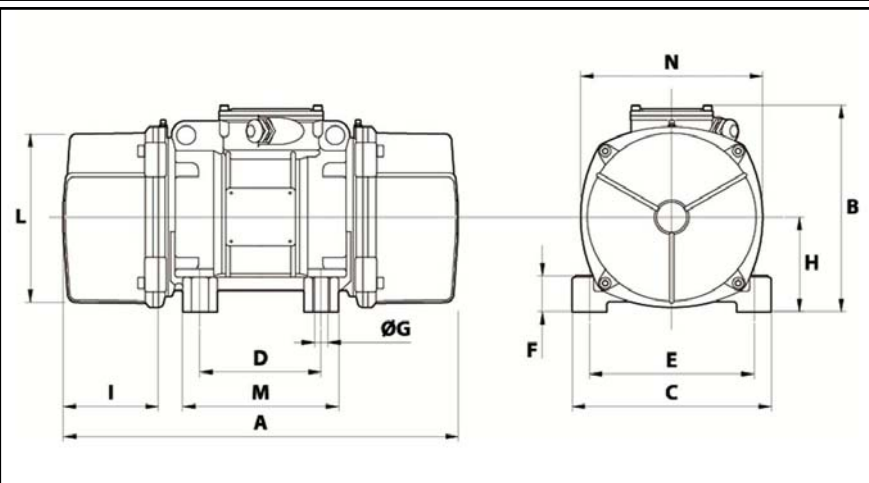

A	249
B	153
C	125
D	62-74**
E	106
F	24
G	9
N° HOLES	4
H	61
I	65
L	103
M	100
N	117

**					
Slot					