

ACBMV B. CASADIO VIBRATION
 Z.I. Mi-Plaine
 51 Rue Ampère
 B.P. 31
 69682 CHASSIEU CEDEX (FRANCE)
 Tel.: 04 78 90 87 87 / Fax.: 04 78 90 87 88
 Email: vibrateur@orange.fr
 Internet: acbmv.com

4 POLES - 1500 RPM ATEX II 2D tD A21 IP 66 ZONE 21-22
 REF.: 601373A Dust T°=120°C
 SIZE: 20

Certifications:



MECHANICAL AND ELECTRICAL SPECIFICATIONS

Eccentric weight setup (%)	Static moment (kgmm)	Working moment (kgcm)	Centrifugal force (kg)	Centrifugal force (kN)	Estimated bearings life time (hours)
100	219,00	43,80	552	5,42	6620
90	197,10	39,42	497	4,88	9070
80	175,20	35,04	442	4,34	12895
70	153,30	30,66	386	3,79	19360
60	131,40	26,28	331	3,25	30704
50	109,50	21,90	276	2,71	52960
40	87,60	17,52	221	2,17	>100000
30	65,70	13,14	166	1,63	>100000
20	43,80	8,76	110	1,08	>100000
10	21,90	4,38	55	0,54	>100000

Power supply (volts)	400
Phases:	three phases
Frequency (Hz)	50 Hz
Rotation speed (RPM)	1500
Max input power (watt)	300
Max current (amp)	0,60
IS/IR	3,33

DIMENSIONAL SPECIFICATIONS (mm)

Vibrator weight: 20,4 kg

Continual service ambient temperature: -20°C à +40°C - Tropicalization anti-mold - Mechanical protection: IP66 IK08 according to IEC

Bearing type: BALL

Lubrication "FOR LIFE" with double protection screen

Fixing with 4 screws M12 - 1/2" quality 8.8 with tightening torque (kgm - ft/lb): 8 - 58

Power supply cable size: 9 à 16 mm - Cable entry thread: M25x1,5

Maintenance space: 114 mm

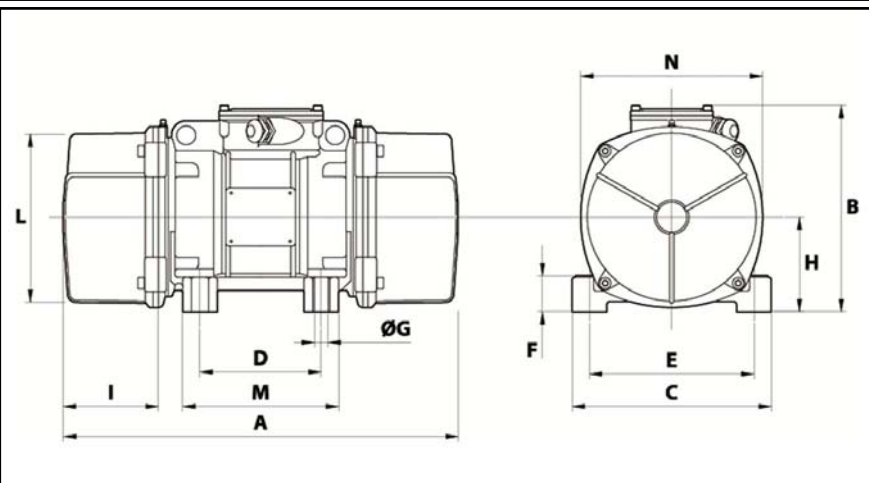

A	386
B	203
C	167
D	105
E	140
F	30
G	13
N° HOLES	4
H	83
I	114
L	145
M	140
N	160