

VIBRATOR TYPE: VB 15/5000-LM 260/460 VOLTS THREE PHASES 60 Hz

ACBMV B. CASADIO VIBRATION
 Z.I. Mi-Plaine
 51 Rue Ampère
 B.P. 31
 69682 CHASSIEU CEDEX (FRANCE)
 Tel.: 04 78 90 87 87 / Fax.: 04 78 90 87 88
 Email: vibrateur@orange.fr
 Internet: acbm.com

4 POLES - 1800 RPM ATEX II 2D tD A21 IP 66 ZONE 21-22
 REF.: 601378C Dust T°=135°C

Certifications:



MECHANICAL AND ELECTRICAL SPECIFICATIONS

Eccentric weight setup (%)		Centrifugal force (kg)	Centrifugal force (kN)	Estimated bearings life time (hours)
100		5000	49	N/A
90		4500	44,10	N/A
80		4000	39,20	N/A
70		3500	34,30	N/A
60		3000	29,40	N/A
50		2500	24,50	N/A
40		2000	19,60	N/A
30		1500	14,70	N/A
20		1000	9,80	N/A
10		500	4,90	N/A

Power supply (volts)	460
Phases:	three phases
Frequency (Hz)	60 Hz
Rotation speed (RPM)	1800
Max input power (watt)	3400
Max current (amp)	5
IS/IR	8

DIMENSIONAL SPECIFICATIONS (mm)

Vibrator weight: 101 kg

Continual service ambient temperature: -20°C à +40°C - Tropicalization anti-mold - Mechanical protection: IP66 IK08 according to IEC

Bearing type: ROLLER

Lubrication LONG-LIFE with KLUEBER STABURAGS NBU 8EP.

Power supply cable size: 9 à 16 mm - Cable entry thread: M32x1,5

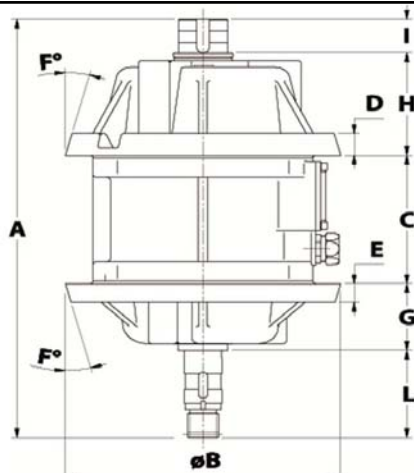

A	555
B	342
C	208
D	48
E	48
F	25
G	106,5
H	110
I	60,5
L	70