

ACBMV B. CASADIO VIBRATION
 Z.I. Mi-Plaine
 51 Rue Ampère
 B.P. 31
 69682 CHASSIEU CEDEX (FRANCE)
 Tel.: 04 78 90 87 87 / Fax.: 04 78 90 87 88
 Email: vibrateur@orange.fr
 Internet: acbmv.com

4 POLES - 1800 RPM
 REF.: 601411C
 SIZE: 20

Certifications:



MECHANICAL AND ELECTRICAL SPECIFICATIONS

Eccentric weight setup (%)	Static moment (kgmm)	Working moment (kgcm)	Centrifugal force (kg)	Centrifugal force (kN)	Estimated bearings life time (hours)
100	163	32,60	592	5,81	4224
90	146,70	29,34	533	5,23	5788
80	130,40	26,08	474	4,65	8229
70	114,10	22,82	414	4,07	12351
60	97,80	19,56	355	3,49	19589
50	81,50	16,30	296	2,91	33792
40	65,20	13,04	237	2,32	65833
30	48,90	9,78	178	1,74	>100000
20	32,60	6,52	118	1,16	>100000
10	16,30	3,26	59	0,58	>100000

Power supply (volts)	260
Phases:	single phase
Frequency (Hz)	60 Hz
Rotation speed (RPM)	1800
Max input power (watt)	Input: 320 Rating: 180
Max current (amp)	2,8
IS/IR	2,5

DIMENSIONAL SPECIFICATIONS (mm)

Vibrator weight: 22 kg

Continual service ambient temperature: -20°C à +40°C - Tropicalization anti-mold - Mechanical protection: IP66 IK08 according to IEC

Bearing type: BALL

Lubrication "FOR LIFE" with double protection screen

Fixing with 4 screws M12 - 1/2" quality 8.8 with tightening torque (kgm - ft/lb): 8 - 58

- Thread (pipe thread not supplied): NPT1/2"

Maintenance space: 117 mm

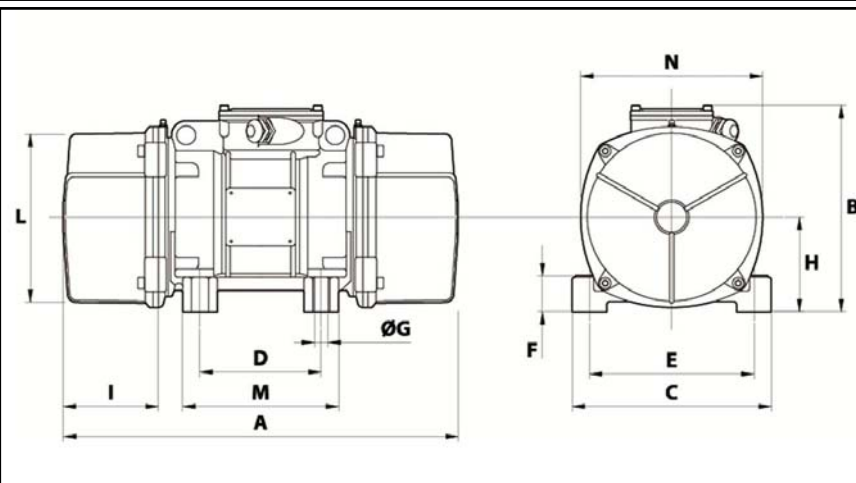

A	392
B	218
C	167
D	105
E	140
F	30
G	13
N° HOLES	4
H	90
I	117
L	150
M	140
N	175