

ACBMV B. CASADIO VIBRATION  
 Z.I. Mi-Plaine  
 51 Rue Ampère  
 B.P. 31  
 69682 CHASSIEU CEDEX (FRANCE)  
 Tel.: 04 78 90 87 87 / Fax.: 04 78 90 87 88  
 Email: [vibrateur@orange.fr](mailto:vibrateur@orange.fr)  
 Internet: [acbmv.com](http://acbmv.com)

4 POLES - 1500 RPM  
 REF.: 601412A  
 SIZE: 30

Certifications:



### MECHANICAL AND ELECTRICAL SPECIFICATIONS

Eccentric weight setup (%)	Static moment (kgmm)	Working moment (kgcm)	Centrifugal force (kg)	Centrifugal force (kN)	Estimated bearings life time (hours)
100	286	57,20	720	7,06	17199
90	257,40	51,48	648	6,35	23593
80	228,80	45,76	576	5,65	33592
70	200,20	40,04	504	4,94	50143
60	171,60	34,32	432	4,24	79625
50	143,00	28,60	360	3,53	>100000
40	114,40	22,88	288	2,82	>100000
30	85,80	17,16	216	2,12	>100000
20	57,20	11,44	144	1,41	>100000
10	28,60	5,72	72	0,71	>100000

Power supply (volts)	400
Phases:	three phases
Frequency (Hz)	50 Hz
Rotation speed (RPM)	1500
Max input power (watt)	Input: 525 Rating: 380
Max current (amp)	0,92
IS/IR	3,48

### DIMENSIONAL SPECIFICATIONS (mm)

**Vibrator weight: 30,3 kg**

Continual service ambient temperature: -20°C à +40°C - Tropicalization anti-mold - Mechanical protection: IP66 IK08 according to IEC

Bearing type: BALL

Lubrication "FOR LIFE" with double protection screen

Fixing with 4 screws M16 - 5/8" quality 8.8 with tightening torque (kgm - ft/lb): 19 - 137

- Thread (pipe thread not supplied): NPT1/2"

Maintenance space: 106 mm

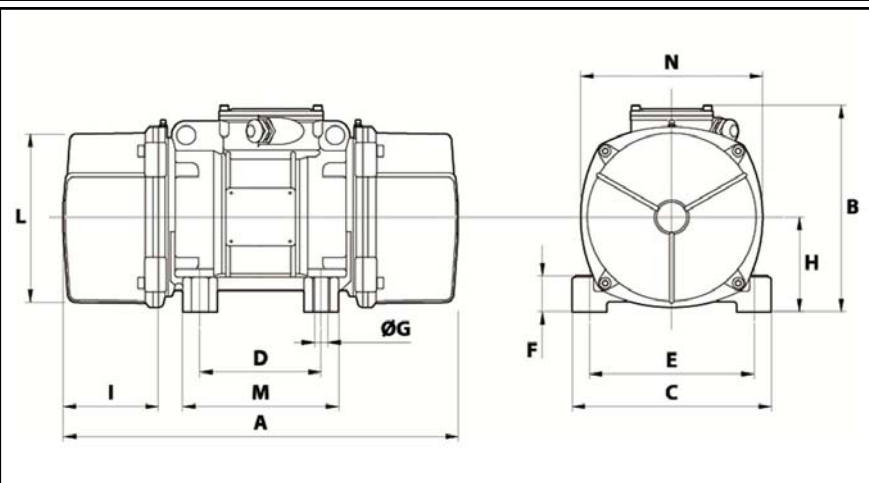

A	394
B	230,5
C	205
D	120
E	170
F	45
G	17
N° HOLES	4
H	102
I	106
L	177
M	162
N	200