

ACBMV B. CASADIO VIBRATION  
 Z.I. Mi-Plaine  
 51 Rue Ampère  
 B.P. 31  
 69682 CHASSIEU CEDEX (FRANCE)  
 Tel.: 04 78 90 87 87 / Fax.: 04 78 90 87 88  
 Email: [vibrateur@orange.fr](mailto:vibrateur@orange.fr)  
 Internet: [acbm.com](http://acbm.com)

6 POLES - 1000 RPM      ATEX II 2D tD A21 IP 66 ZONE 21-22  
 REF.: 602171A              Dust T°=150°C

Certifications:



### MECHANICAL AND ELECTRICAL SPECIFICATIONS

Eccentric weight setup (%)			Centrifugal force (kg)	Centrifugal force (kN)	Estimated bearings life time (hours)
100			-	-	
90					
80					
70					
60					
50					
40					
30					
20					
10					

Power supply (volts)	400
Phases:	three phases
Frequency (Hz)	50 Hz
Rotation speed (RPM)	1000
Max input power (watt)	-
Max current (amp)	-
IS/IR	-

### DIMENSIONAL SPECIFICATIONS (mm)

**Vibrator weight: 68 kg**

Continual service ambient temperature: -20°C à +40°C - Tropicalization anti-mold - Mechanical protection: IP66 IK08 according to IEC  
 Bearing type: ROLLER  
 Lubrication LONG-LIFE with KLUEBER STABURAGS NBU 8EP.  
 Re lubrication quantity after 1000 hours of using: 30g  
 Max quantity by replaced bearing: 60g

Power supply cable size: 9 à 16 mm - Cable entry thread: M32x1,5

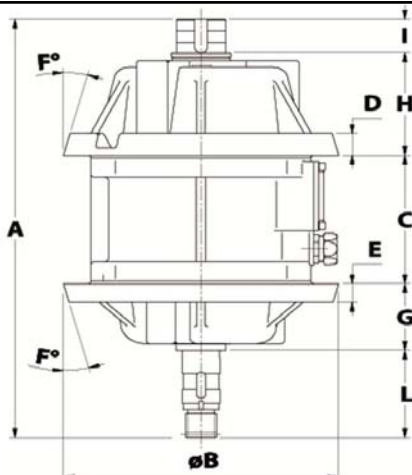

A	517,5
B	281
C	152,5
D	30
E	26
F	14
G	85,3
H	136,6
I	35
L	108